

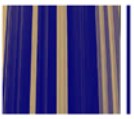

Profiles

Perfiles



Profiles - *Perfiles*

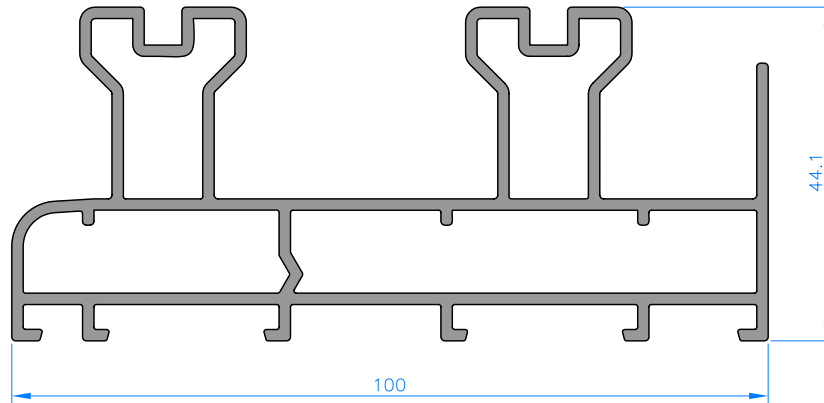

10001

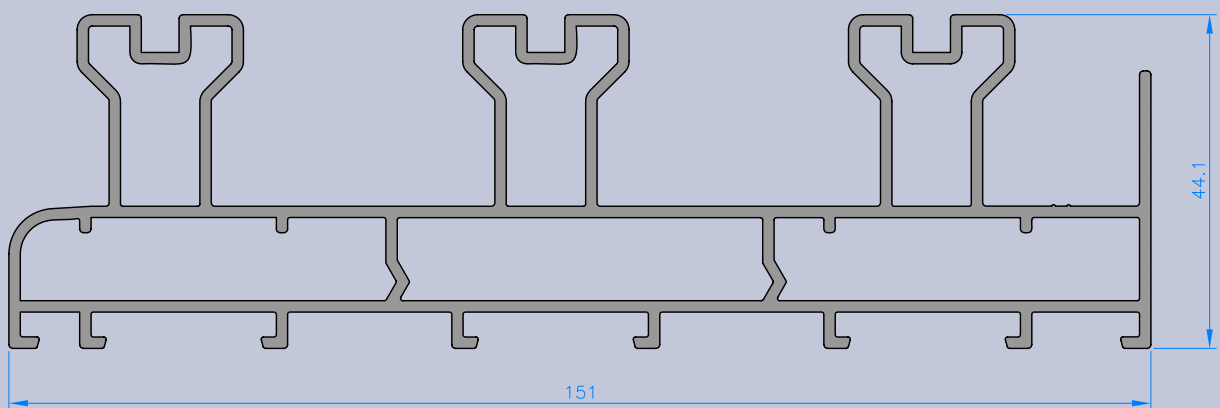

10030

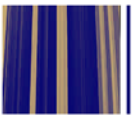

Profiles - *Perfiles*

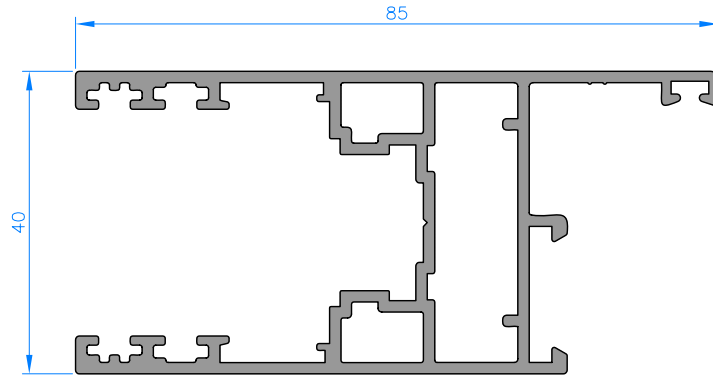

10060

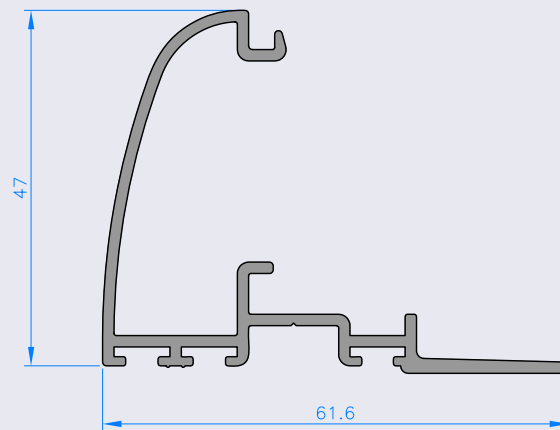

10004

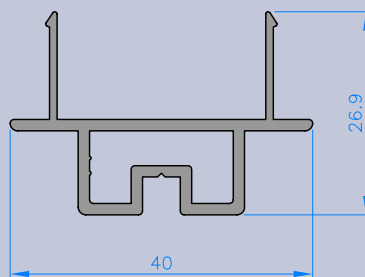

10041



Profiles - *Perfiles*

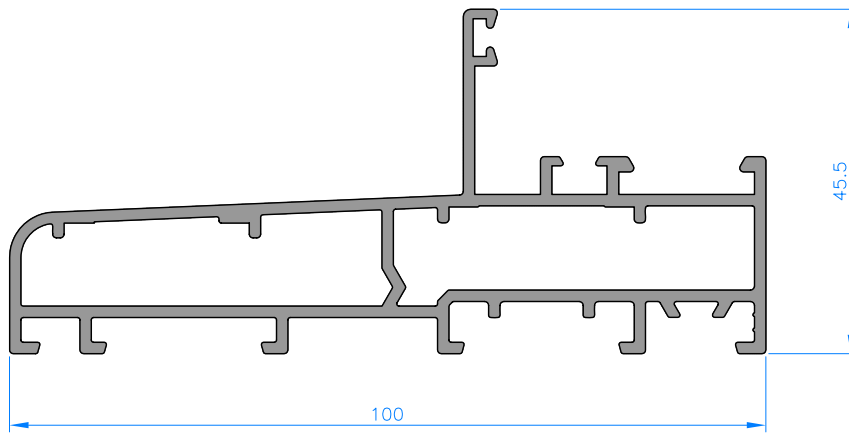

10080

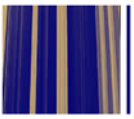

Profiles - *Perfiles*

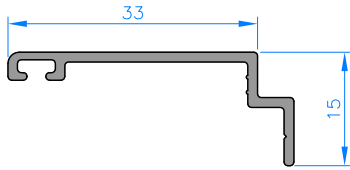

72701

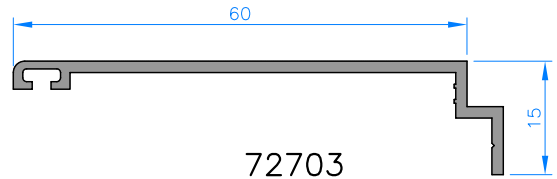

72703

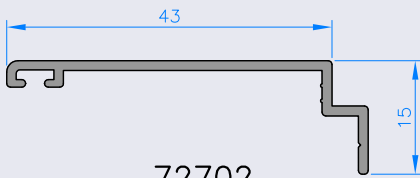

72702

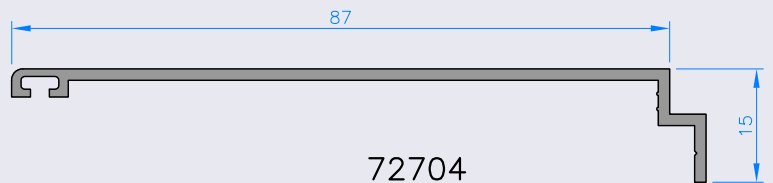

72704

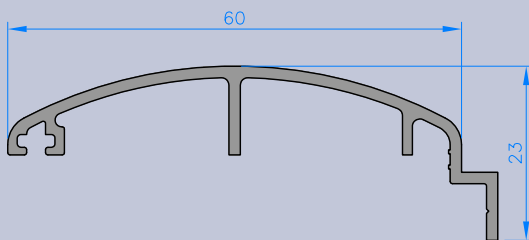

72708

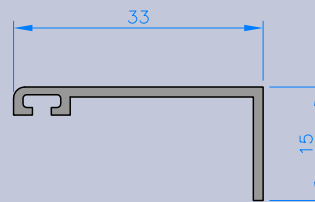

72800*

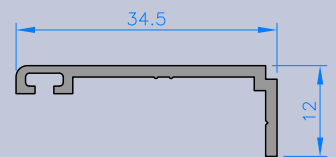

72801

* Consultar existencias o pedido mínimo

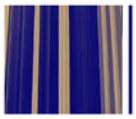

Profiles - Perfiles

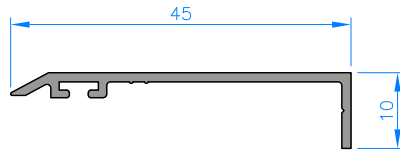

72802

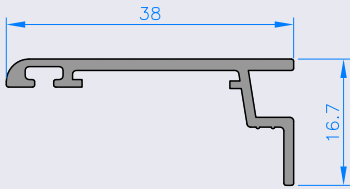

72804

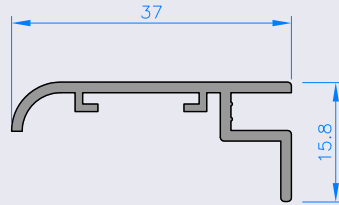

72803

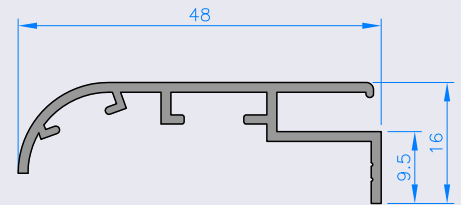

72481

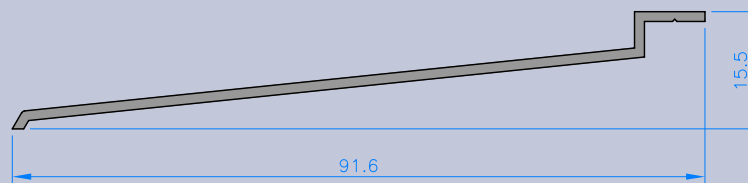

4657*

* Consultar existencias o pedido mínimo



Glazing

Acristalamiento

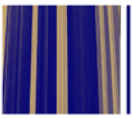

Glazing - Acristalamiento

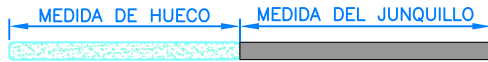

Para calcular el vidrio:

Descontar la medida de juntas, según indicaciones del fabricante.

9998216		3 MM FIN EXT. GLAZING JOINT JUNTA ACRISTALAMIENTO EXTERIOR DE 3 MM.
9998226		6 MM FIN EXT. GLAZING JOINT JUNTA ACRISTALAMIENTO EXTERIOR DE 6 MM.
9998236		3 MM FIN INT. GLAZING JOINT JUNTA ACRISTALAMIENTO DE CUÑA DE 3 MM.
9998246		4 MM FIN INT. GLAZING JOINT JUNTA ACRISTALAMIENTO DE CUÑA DE 4 MM.
9998256		5 MM FIN INT. GLAZING JOINT JUNTA ACRISTALAMIENTO DE CUÑA DE 5 MM.
9998266		6/7 MM FIN INT. GLAZING JOINT JUNTA ACRISTALAMIENTO DE CUÑA DE 6/7 MM.
9998286		8/9 MM FIN INT. GLAZING JOINT JUNTA ACRISTALAMIENTO DE CUÑA DE 8/9 MM.
9998296		10 MM FIN INT. GLAZING JOINT JUNTA ACRISTALAMIENTO DE CUÑA DE 10 MM.

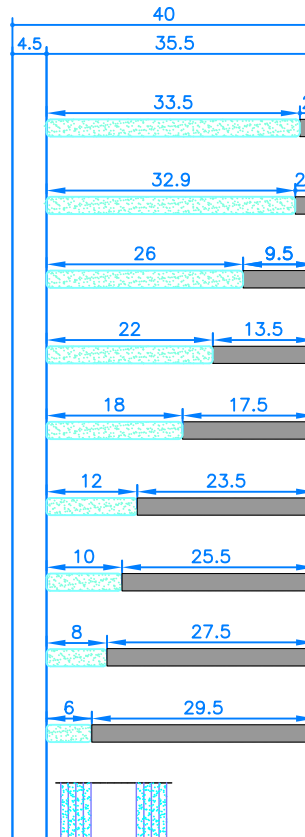

102308		
	940305	
940304	940314	940324
940303	940313	940323
940302	940312	940322
940301	940311	940321
940306		
850307		
940300	940310	940320

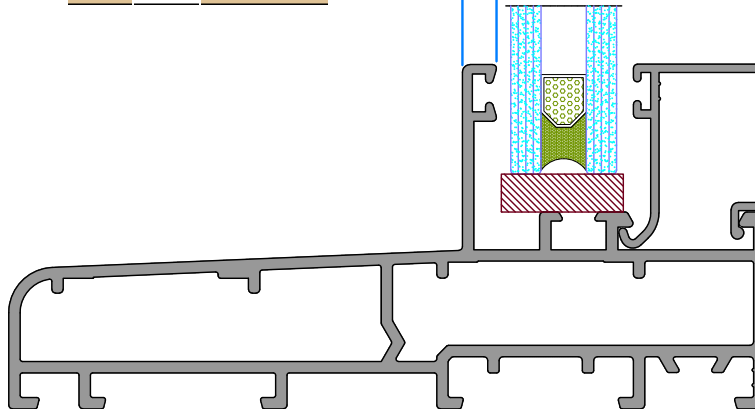

MEASURES OF HOLLOW FOR GLASSES

MEDIDAS DE HUECO PARA VIDRIO

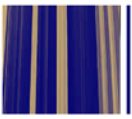

Glazing - Acristalamiento

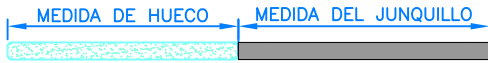

Para calcular el vidrio:

Descontar la medida de juntas, según indicaciones del fabricante.

9998216		3 MM FIN EXT. GLAZING JOINT JUNTA ACRISTALAMIENTO EXTERIOR DE 3 MM.
9998226		6 MM FIN EXT. GLAZING JOINT JUNTA ACRISTALAMIENTO EXTERIOR DE 6 MM.
9998236		3 MM FIN INT. GLAZING JOINT JUNTA ACRISTALAMIENTO DE CUÑA DE 3 MM.
9998246		4 MM FIN INT. GLAZING JOINT JUNTA ACRISTALAMIENTO DE CUÑA DE 4 MM.
9998256		5 MM FIN INT. GLAZING JOINT JUNTA ACRISTALAMIENTO DE CUÑA DE 5 MM.
9998266		6/7 MM FIN INT. GLAZING JOINT JUNTA ACRISTALAMIENTO DE CUÑA DE 6/7 MM.
9998286		8/9 MM FIN INT. GLAZING JOINT JUNTA ACRISTALAMIENTO DE CUÑA DE 8/9 MM.
9998296		10 MM FIN INT. GLAZING JOINT JUNTA ACRISTALAMIENTO DE CUÑA DE 10 MM.

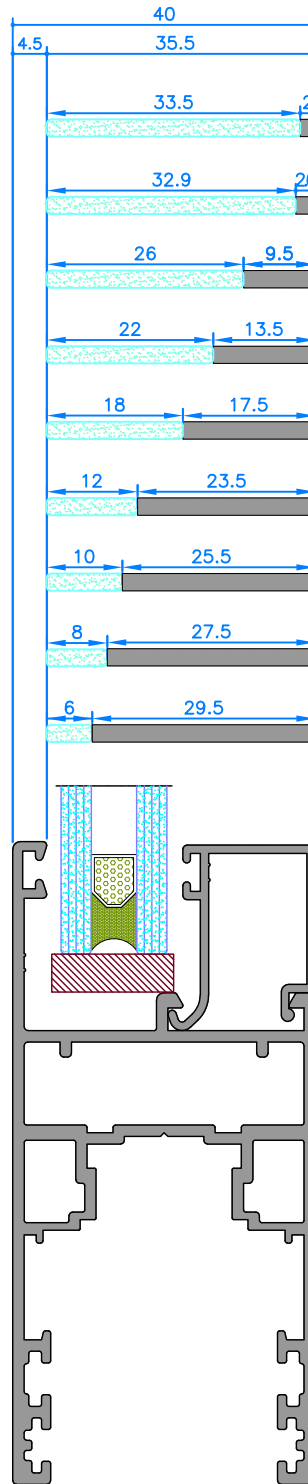

102308		
	940305	
940304	940314	940324
940303	940313	940323
940302	940312	940322
940301	940311	940321
940306		
850307		
940300	940310	940320

MEASURES OF HOLLOW FOR GLASSES

MEDIDAS DE HUECO PARA VIDRIO





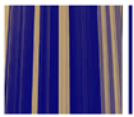

Technical Data

Datos técnicos

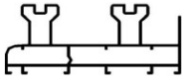

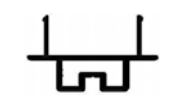
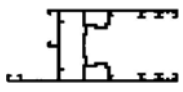
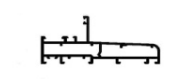

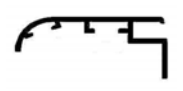
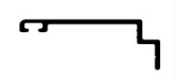
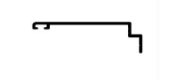
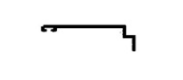
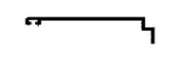



Technical Data - *Datos técnicos*

Reference <i>Referencia</i>	Scheme <i>Esquema</i>	Description <i>Descripción</i>	Weight <i>Peso</i> Kg/Mts	Perimeter <i>Perimetro</i>			Faces <i>Caras</i>	Jx cm. ⁴	Jy cm. ⁴
				ext.	int.	total			
10001		PERIMETRAL FRAME 2 WAYS <i>MARCO PERIMETRAL DE DOS CARRILES</i>	1,863	47,8	42,0	89,8	3	12,67	65,14
10004		CURVED CENTRAL COMPLEMENT <i>SUPLEMENTO CENTRAL CURVO</i>	0,672	32,6	---	32,6	2	3,84	9,39
10030		PERIMETRAL FRAME 3 WAYS <i>MARCO PERIMETRAL DE TRES CARRILES</i>	2,718	67,5	63,4	130,9	3	18,51	210,79
10041		4 SASH PROFILE <i>PERFIL DE CUATRO HOJAS</i>	0,446	17,0	6,7	23,7	2	0,69	1,82
10060		PERIMETRAL SASH <i>HOJA PERIMETRAL</i>	1,351	45,7	18,0	63,7	2	12,21	23,15
10080		PERIMETRAL FIXED <i>FIJO PERIMETRAL</i>	1,439	43,3	25,4	68,7	3	4,88	48,11
4657*		EXTENSION PROFILE <i>PERFIL ALARGADERA</i>	0,344	19,7	---	19,7	1	0,02	9,42
72481		47 mm CURVED OVERLAP <i>SOLAPE CURVO DE 47 mm</i>	0,336	---	---	19,7	2	0,17	2,83
72701		33 mm OVERLAP <i>SOLAPE DE 33 mm</i>	0,199	---	---	11,7	1	0,06	1,20
72702		43 mm OVERLAP <i>SOLAPE DE 43 mm</i>	0,234	---	---	13,7	1	0,07	2,23
72703		60 mm OVERLAP <i>SOLAPE DE 60 mm</i>	0,333	---	---	17,4	1	0,10	5,48
72704		87 mm OVERLAP <i>SOLAPE DE 87 mm</i>	0,443	---	---	22,8	1	0,11	14,14

* Consultar existencias o pedido mínimo

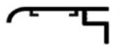

Technical Data - *Datos técnicos*

Reference <i>Referencia</i>	Scheme <i>Esquema</i>	Description <i>Descripción</i>	Weight <i>Peso</i> Kg/Mts	Perimeter <i>Perimetro</i> ext.	Perimeter int.	Perimeter total	Faces <i>Caras</i>	Jx cm. ⁴	Jy cm. ⁴
72708		60 mm CURVED OVERLAP <i>SOLAPE CURVO DE 60 mm</i>	0,428	---	---	21,4	1	0,36	6,73
72800*		33 mm SUPERIOR OVERLAP <i>SOLAPE SUPERIOR 33 mm</i>	0,200	---	---	10,9	1	0,07	0,92
72801		33 mm OVERLAP <i>SOLAPE DE 33 mm</i>	0,197	---	---	10,7	1	0,05	0,99
72802		45 mm OVERLAP <i>SOLAPE DE 45 mm</i>	0,195	---	---	12,3	1	0,03	1,52
72803		37 mm OVERLAP <i>SOLAPE DE 37 mm</i>	0,259	---	---	14,4	1	0,11	1,31
72804		38 mm OVERLAP <i>SOLAPE DE 38 mm</i>	0,251	---	---	13,6	1	0,11	1,47

* Consultar existencias o pedido mínimo







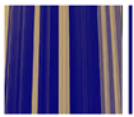



o

o



Accessories - Accesorios

ACCESSORIES - ACCESORIOS			DAI SYSTEM	V-94	V-98	V-98RT45	SM-54RT	V-98RT67	SM65 OCULTA	SM-85RT	SM-95 RF+AB	42200	MALLORQUINA	MALL-COR	IP50	MURO	CONTRAVENTANA	2300	640	700	800	IGV909	IC60	IC70	IC75RT	ELV100	SM-100RT	SM-135RT	RUSTICA	S35	BARANA	BARANDILLA
CODE CODIGO	DRAWING FIGURA	DESCRIPTION DESCRIPCIÓN																														
1356251		HEIGHT SUPPLEMENT UNTIL 3300mm. SUPLEMENTO ALTURA HASTA 3300 MM.																								•		•				
1006322		ELEVABLE CART PLUG HS200 CALZO CARRO ELEVABLE HS200																								•						
1006330		ACCESORIES BAG HS200 BOLSA ACCESORIOS HS200																								•						
1356502		MULTIPOINT HANDLE L-600 CREMONA CORRED.LINEA L-600																					•		•	•	•					
1356512		MULTIPOINT HANDLE L-600 CREMONA CORRED.LINEA L-600																						•		•	•	•				
1006522		LOCKING ELEVABLE HS200 11mm CERRADERO ELEVABLE HS200 DE 11 MM. PARA ELV-100																								•						
1006542		LOCKING ELEVABLE VENTILATION HS200 11mm CERRADERO VENTILACION ELEVABLE HS200 DE 11 MM. PARA ELV-100																								•						
1006553		SASH PLUG FOR LINE SLIDING CALZO HOJA PARA CORREDERA LINEA SERIE ELV-100																								•						
1006563		FRAME PLUG FOR LINE SLIDING CALZO MARCO PARA CORREDERA LINEA SERIE ELV-100																								•						

