

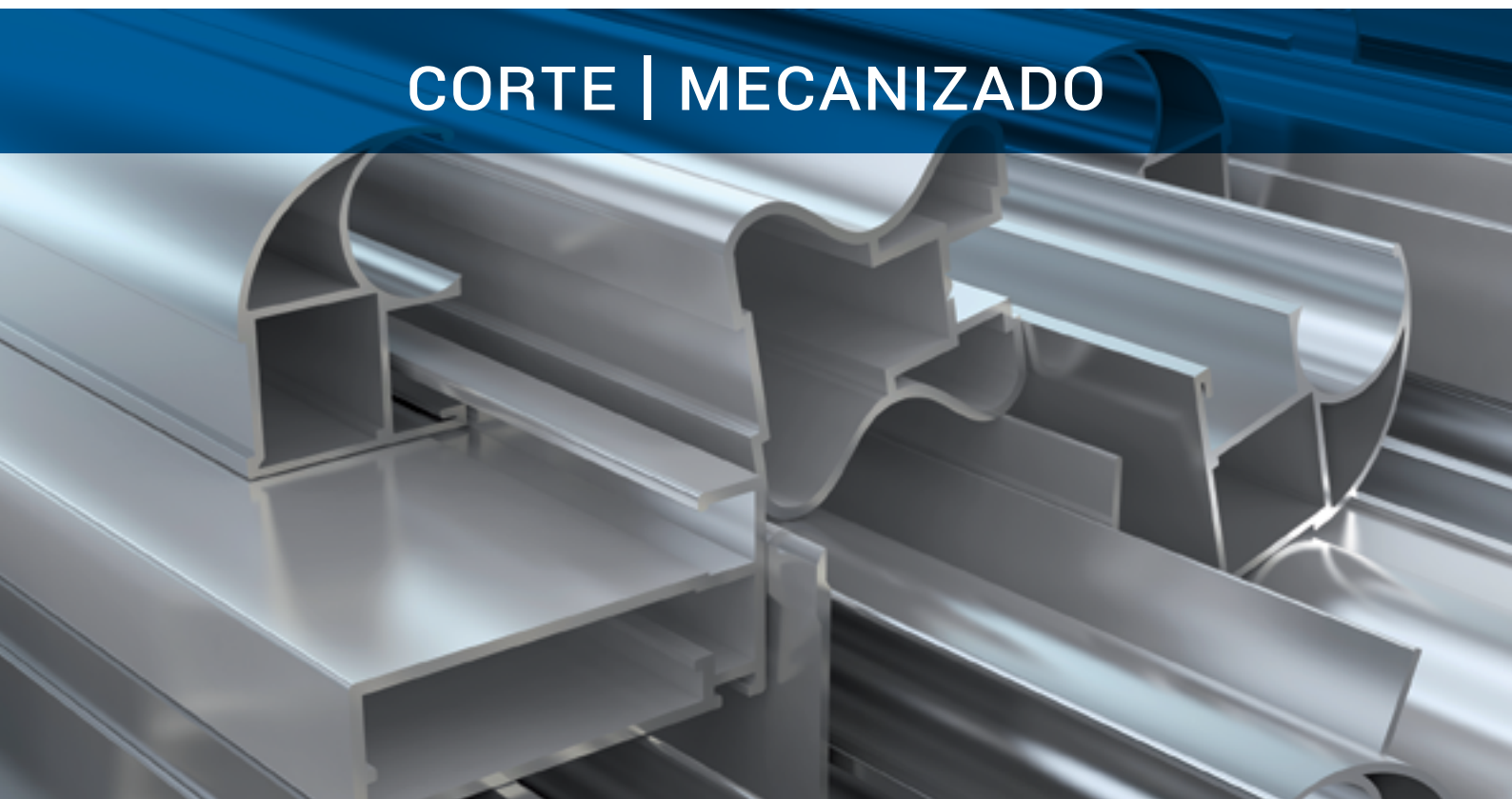

CORREDERA DE CORTE RECTO
STRAIGHT CUT SLIDING

Serie 800

CORTE | MECANIZADO





ESQUEMAS DE CORTE | CUTTING SCHEMES

Corte de dos carriles con fijo independiente

Two ways cutting with fixed independent

CON MARCO LATERAL 800030, 800032 800033

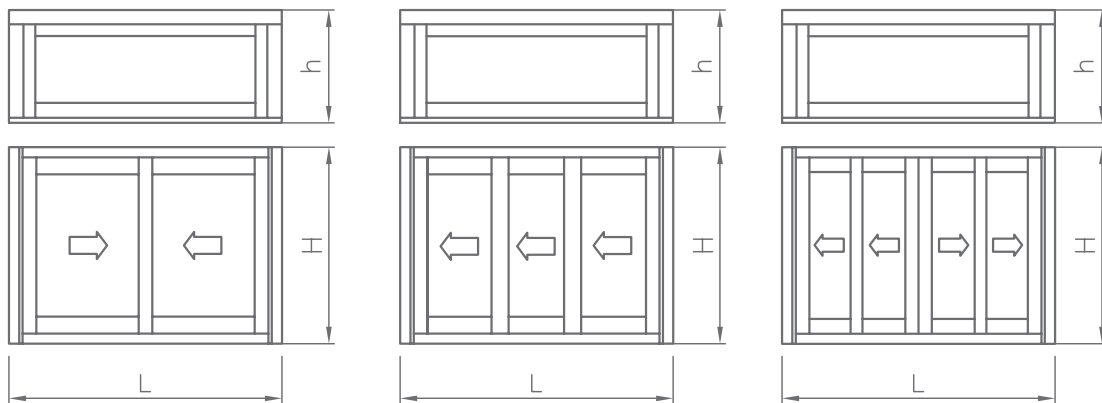

PERFILES – LONGITUDES DE CORTE								
PERFIL	FIGURA	DESCRIPCION	2 HOJAS		3 HOJAS		4 HOJAS	
			CANT.	CORTE	CANT.	CORTE	CANT.	CORTE
800010		MARCO SUPERIOR	1	L-42	1	L-42	1	L-42
800020		MARCO INFERIOR	1	L-42	1	L-42	1	L-42
800030		MARCO LATERAL	2	H	2	H	2	H
800040		HOJA LATERAL CRISTAL NORMAL	2	H-66	2	H-66	4	H-66
800045		HOJA LATERAL CRISTAL CAMARA	2	H-66	2	H-66	4	H-66
800050		HOJA CENTRAL CRISTAL NORMAL	2	H-66	4	H-66	4	H-66
800055		HOJA CENTRAL CRISTAL CAMARA	2	H-66	4	H-66	4	H-66
800060		HOJA DE RUEDA CRISTAL NORMAL	4	L/2 -17	6	L/3 +3	8	L/4 -8
800065		HOJA DE RUEDA CRISTAL CAMARA	4	L/2 -17	6	L/3 +3	8	L/4 -8
800070		ZOCALO CRISTAL NORMAL	2	L/2 -17	3	L/3 +3	4	L/4 -8
800075		ZOCALO CRISTAL CAMARA	2	L/2 -17	3	L/3 +3	4	L/4 -8
900384		MARCO FIJO SIN CLIP	2	h-40	2	h-40	2	h-40
900384		MARCO FIJO SIN CLIP	1	L	1	L	1	L
800090		MARCO FIJO CON CLIP	1	L	1	L	1	L
800400		PERFIL 4 HOJAS					1	H-66
800401		DIVISOR CRISTAL NORMAL	2	L/2 -17	3	L/3 +3	4	L/4 -8
800402		DIVISOR CRISTAL CAMARA	2	L/2 -17	3	L/3 +3	4	L/4 -8
VARIOS		JUNQUILLO	2	L-40	2	L-40	2	L-40
VARIOS		JUNQUILLO	2	h-84	2	h-84	2	h-84



ESQUEMAS DE CORTE | CUTTING SCHEMES

Corte de dos carriles con fijo clipado

Two ways cutting with fixed clipping

CON MARCO LATERAL 800030, 800032 800033

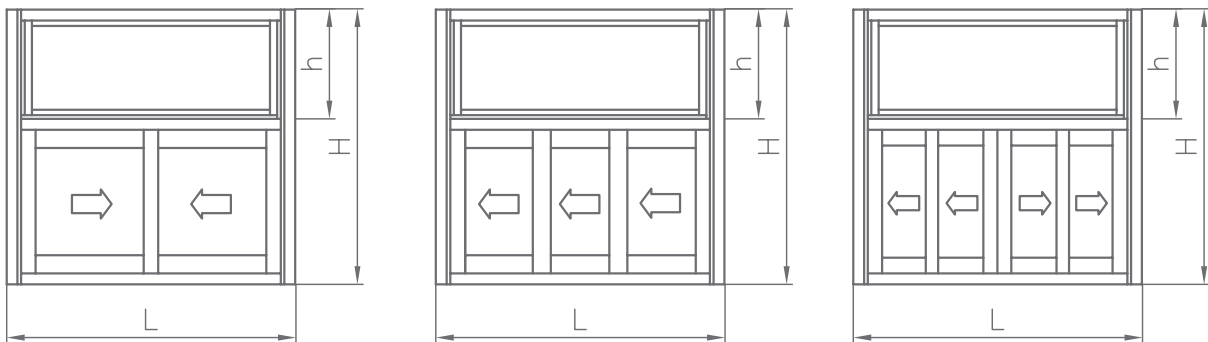

PERFILES – LONGITUDES DE CORTE								
PERFIL	FIGURA	DESCRIPCION	2 HOJAS		3 HOJAS		4 HOJAS	
			CANT.	CORTE	CANT.	CORTE	CANT.	CORTE
800010		MARCO SUPERIOR	1	L-42	1	L-42	1	L-42
800020		MARCO INFERIOR	1	L-42	1	L-42	1	L-42
800030		MARCO LATERAL	2	H	2	H	2	H
800040		HOJA LATERAL CRISTAL NORMAL	2	H-h-66	2	H-h-66	4	H-h-66
800045		HOJA LATERAL CRISTAL CAMARA	2	H-h-66	2	H-h-66	4	H-h-66
800050		HOJA CENTRAL CRISTAL NORMAL	2	H-h-66	4	H-h-66	4	H-h-66
800055		HOJA CENTRAL CRISTAL CAMARA	2	H-h-66	4	H-h-66	4	H-h-66
800060		HOJA DE RUEDA CRISTAL NORMAL	4	L/2 -17	6	L/3 +3	8	L/4 -8
800065		HOJA DE RUEDA CRISTAL CAMARA	4	L/2 -17	6	L/3 +3	8	L/4 -8
800070		ZOCALO CRISTAL NORMAL	2	L/2 -17	3	L/3 +3	4	L/4 -8
800075		ZOCALO CRISTAL CAMARA	2	L/2 -17	3	L/3 +3	4	L/4 -8
900384		MARCO FIJO SIN CLIP	2	h-40	2	h-40	2	h-40
900384		MARCO FIJO SIN CLIP	1	L-42	1	L-42	1	L-42
800090		MARCO FIJO CON CLIP	1	L-42	1	L-42	1	L-42
800400		PERFIL 4 HOJAS					1	H-h-66
800401		DIVISOR CRISTAL NORMAL	2	L/2 -17	3	L/3 +3	4	L/4 -8
800402		DIVISOR CRISTAL CAMARA	2	L/2 -17	3	L/3 +3	4	L/4 -8
VARIOS		JUNQUILLO	2	L-92	2	L-92	2	L-92
VARIOS		JUNQUILLO	2	h-84	2	h-84	2	h-84



ESQUEMAS DE CORTE | CUTTING SCHEMES

Corte de tres carriles con fijo independiente

Three ways cutting with fixed independent



PERFILES – LONGITUDES DE CORTE						
PERFIL	FIGURA	DESCRIPCION	3 HOJAS		6 HOJAS	
			CANT.	CORTE	CANT.	CORTE
800040		HOJA LATERAL CRISTAL NORMAL	2	H-66	4	H-66
800045		HOJA LATERAL CRISTAL CAMARA	2	H-66	4	H-66
800050		HOJA CENTRAL CRISTAL NORMAL	4	H-66	8	H-66
800055		HOJA CENTRAL CRISTAL CAMARA	4	H-66	8	H-66
800060		HOJA DE RUEDA CRISTAL NORMAL	6	L/3 +3	12	L/6 +11
800065		HOJA DE RUEDA CRISTAL CAMARA	6	L/3 +3	12	L/6 +11
800070		ZOCALO CRISTAL NORMAL	3	L/3 +3	6	L/6 +11
800075		ZOCALO CRISTAL CAMARA	3	L/3 +3	6	L/6 +11
800310		MARCO SUPERIOR TRES CARRILES	1	L-42	1	L-42
800320		MARCO INFERIOR TRES CARRILES	1	L-42	1	L-42
800330		MARCO LATERAL TRES CARRILES	2	H	2	H
800400		PERFIL 4 HOJAS			1	H-h-66
800401		DIVISOR CRISTAL NORMAL	3	L/3 +3	6	L/6 +11
800402		DIVISOR CRISTAL CAMARA	3	L/3 +3	6	L/6 +11
10080		MARCO FIJO	2	L	2	L
10080		MARCO FIJO	2	h	2	h
VARIOS		JUNQUILLO	2	L-52	2	L-52
VARIOS		JUNQUILLO	2	h-91	2	h-91



ESQUEMAS DE CORTE | CUTTING SCHEMES

Corte de dos carriles con fijo independiente

Two ways cutting with fixed independent

CON MARCO LATERAL 800031

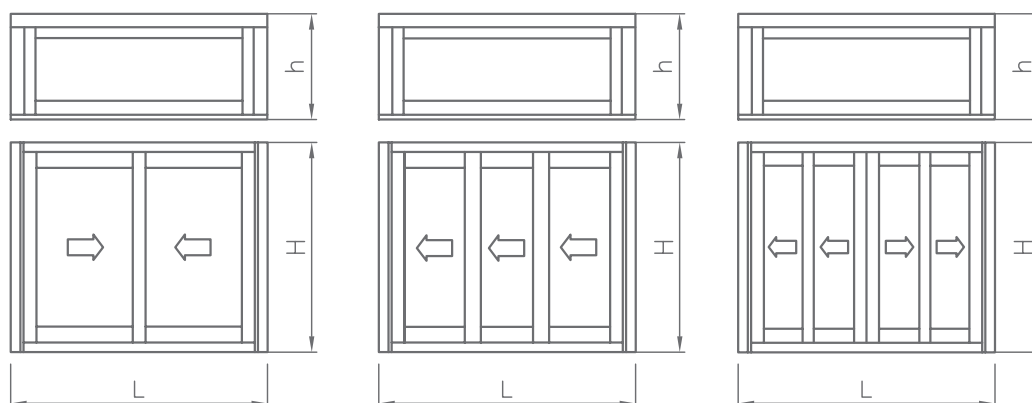

PERFILES – LONGITUDES DE CORTE								
PERFIL	FIGURA	DESCRIPCION	2 HOJAS		3 HOJAS		4 HOJAS	
			CANT.	CORTE	CANT.	CORTE	CANT.	CORTE
800010		MARCO SUPERIOR	1	L-49	1	L-49	1	L-49
800020		MARCO INFERIOR	1	L-49	1	L-49	1	L-49
800031		MARCO LATERAL	2	H	2	H	2	H
800040		HOJA LATERAL CRISTAL NORMAL	2	H-66	2	H-66	4	H-66
800045		HOJA LATERAL CRISTAL CAMARA	2	H-66	2	H-66	4	H-66
800050		HOJA CENTRAL CRISTAL NORMAL	2	H-66	4	H-66	4	H-66
800055		HOJA CENTRAL CRISTAL CAMARA	2	H-66	4	H-66	4	H-66
800060		HOJA DE RUEDA CRISTAL NORMAL	4	L/2 -22	6	L/3 +1	8	L/4 -10
800065		HOJA DE RUEDA CRISTAL CAMARA	4	L/2 -22	6	L/3 +1	8	L/4 -10
800070		ZOCALO CRISTAL NORMAL	2	L/2 -22	3	L/3 +1	4	L/4 -10
800075		ZOCALO CRISTAL CAMARA	2	L/2 -22	3	L/3 +1	4	L/4 -10
900384		MARCO FIJO SIN CLIP	2	h-40	2	h-40	2	h-40
900384		MARCO FIJO SIN CLIP	1	L	1	L	1	L
800090		MARCO FIJO CON CLIP	1	L	1	L	1	L
800400		PERFIL 4 HOJAS					1	H-66
800401		DIVISOR CRISTAL NORMAL	2	L/2 -17	3	L/3 +3	4	L/4 -8
800402		DIVISOR CRISTAL CAMARA	2	L/2 -17	3	L/3 +3	4	L/4 -8
VARIOS		JUNQUILLO	2	L-40	2	L-40	2	L-40
VARIOS		JUNQUILLO	2	h-84	2	h-84	2	h-84



ESQUEMAS DE CORTE | CUTTING SCHEMES

Corte de dos carriles con fijo clipado

Two ways cutting with fixed clipping

CON MARCO LATERAL 800031

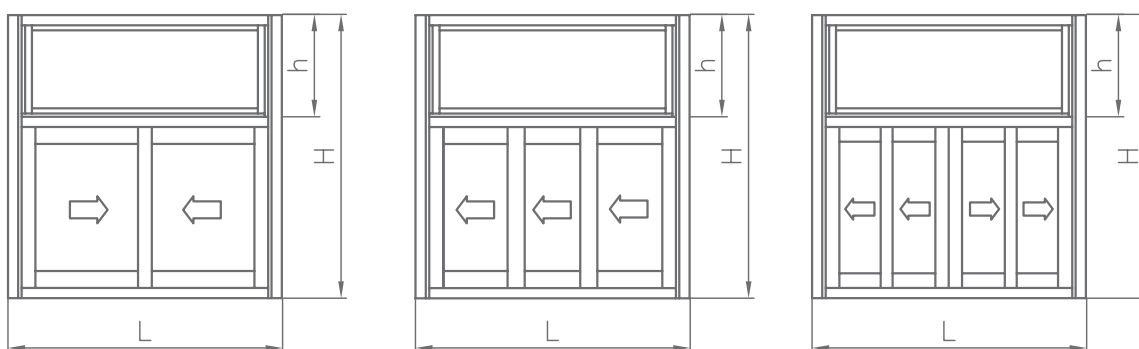

PERFILES – LONGITUDES DE CORTE								
PERFIL	FIGURA	DESCRIPCION	2 HOJAS		3 HOJAS		4 HOJAS	
			CANT.	CORTE	CANT.	CORTE	CANT.	CORTE
800010		MARCO SUPERIOR	1	L-49	1	L-49	1	L-49
800020		MARCO INFERIOR	1	L-49	1	L-49	1	L-49
800031		MARCO LATERAL	2	H	2	H	2	H
800040		HOJA LATERAL CRISTAL NORMAL	2	H-h-66	2	H-h-66	4	H-h-66
800045		HOJA LATERAL CRISTAL CAMARA	2	H-h-66	2	H-h-66	4	H-h-66
800050		HOJA CENTRAL CRISTAL NORMAL	2	H-h-66	4	H-h-66	4	H-h-66
800055		HOJA CENTRAL CRISTAL CAMARA	2	H-h-66	4	H-h-66	4	H-h-66
800060		HOJA DE RUEDA CRISTAL NORMAL	4	L/2 -22	6	L/3 +1	8	L/4 -10
800065		HOJA DE RUEDA CRISTAL CAMARA	4	L/2 -22	6	L/3 +1	8	L/4 -10
800070		ZOCALO CRISTAL NORMAL	2	L/2 -22	3	L/3 +1	4	L/4 -10
800075		ZOCALO CRISTAL CAMARA	2	L/2 -22	3	L/3 +1	4	L/4 -10
900384		MARCO FIJO SIN CLIP	2	h-40	2	h-40	2	h-40
900384		MARCO FIJO SIN CLIP	1	L-42	1	L-42	1	L-42
800090		MARCO FIJO CON CLIP	1	L-42	1	L-42	1	L-42
800400		PERFIL 4 HOJAS					1	H-h-66
800401		DIVISOR CRISTAL NORMAL	2	L/2 -17	3	L/3 +3	4	L/4 -8
800402		DIVISOR CRISTAL CAMARA	2	L/2 -17	3	L/3 +3	4	L/4 -8
VARIOS		JUNQUILLO	2	L-92	2	L-92	2	L-92
VARIOS		JUNQUILLO	2	h-84	2	h-84	2	h-84



MECANIZADOS | MACHINING

Marco superior

Superior frame

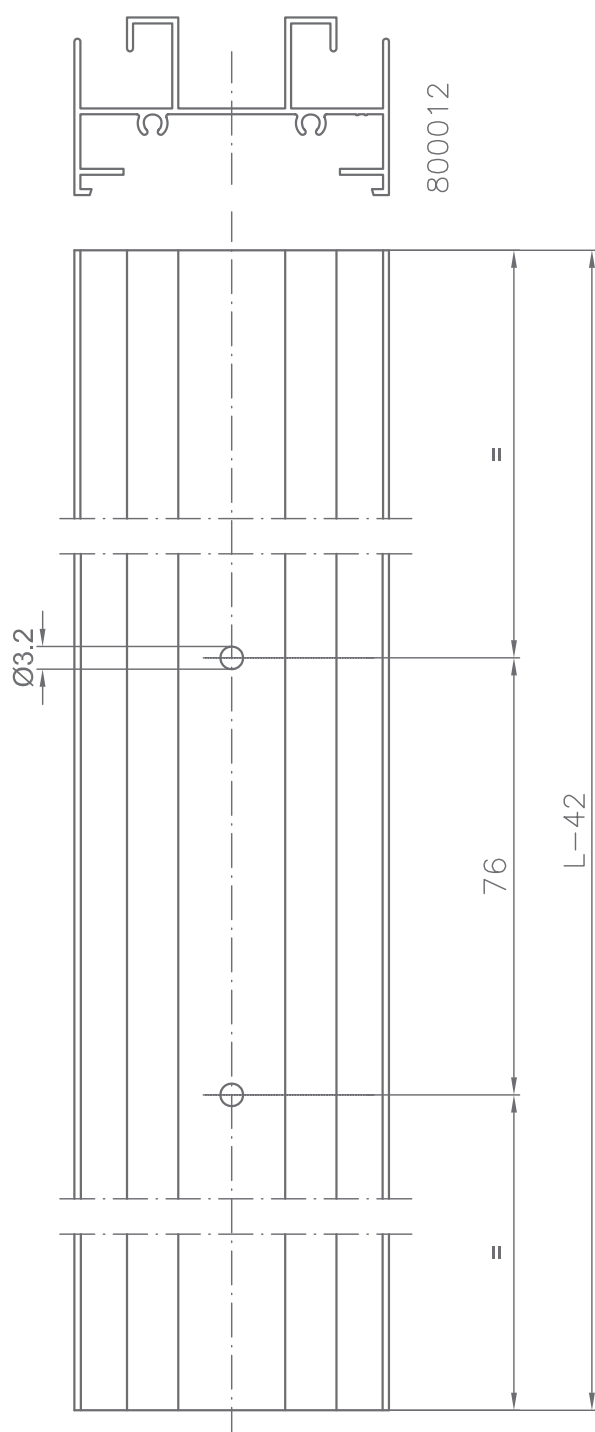

CON MARCO LATERAL

800030

800032

800033

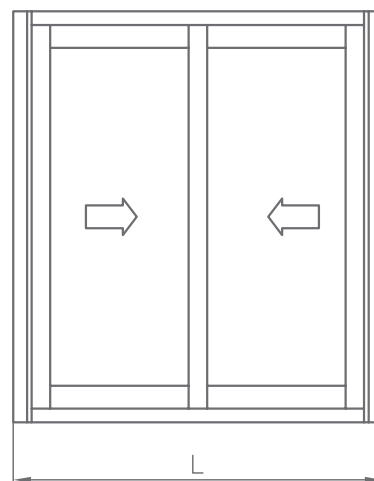



MECANIZADOS | MACHINING

Marco inferior

Inferior frame

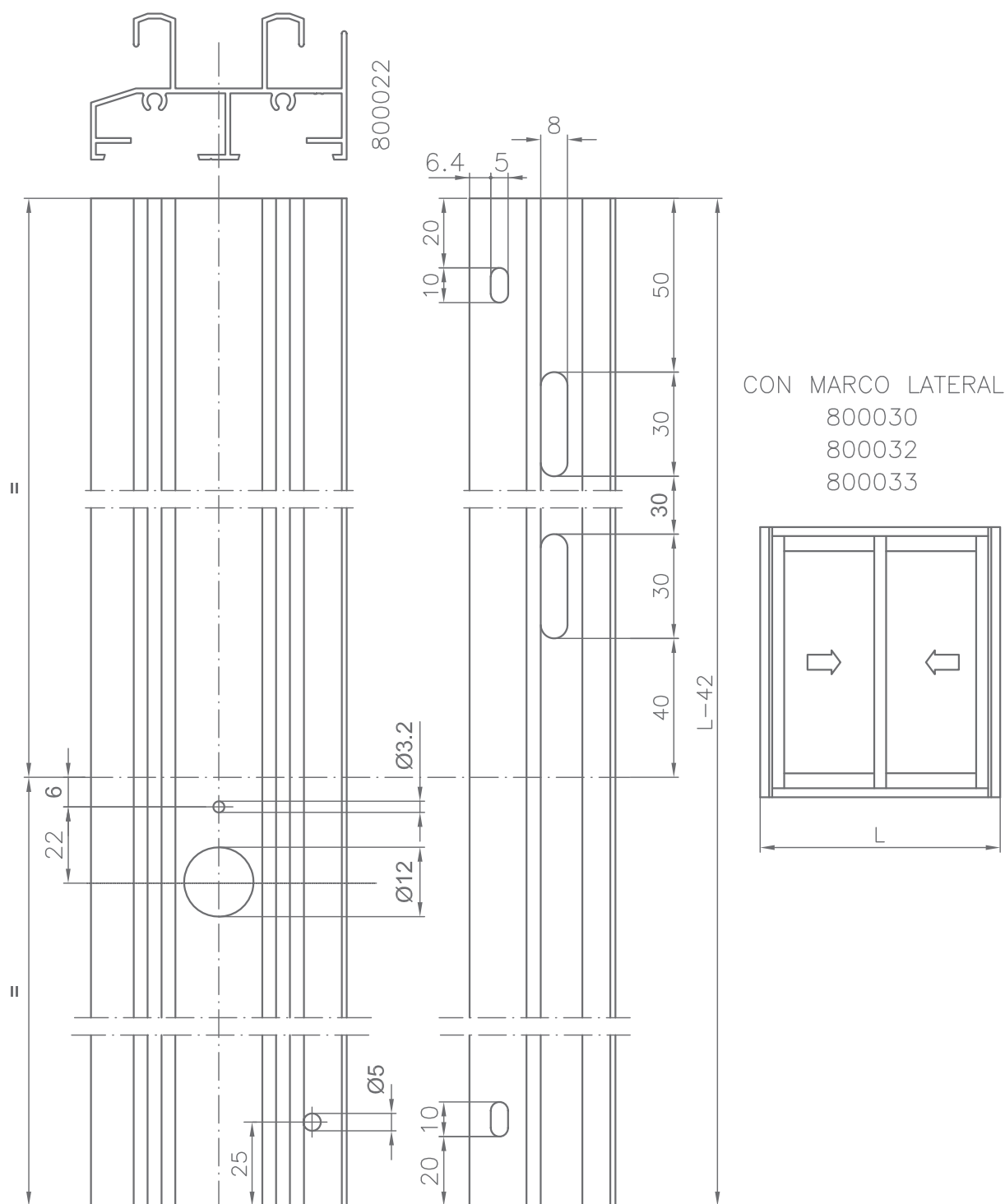



MECANIZADOS | MACHINING

Marco inferior

Inferior frame

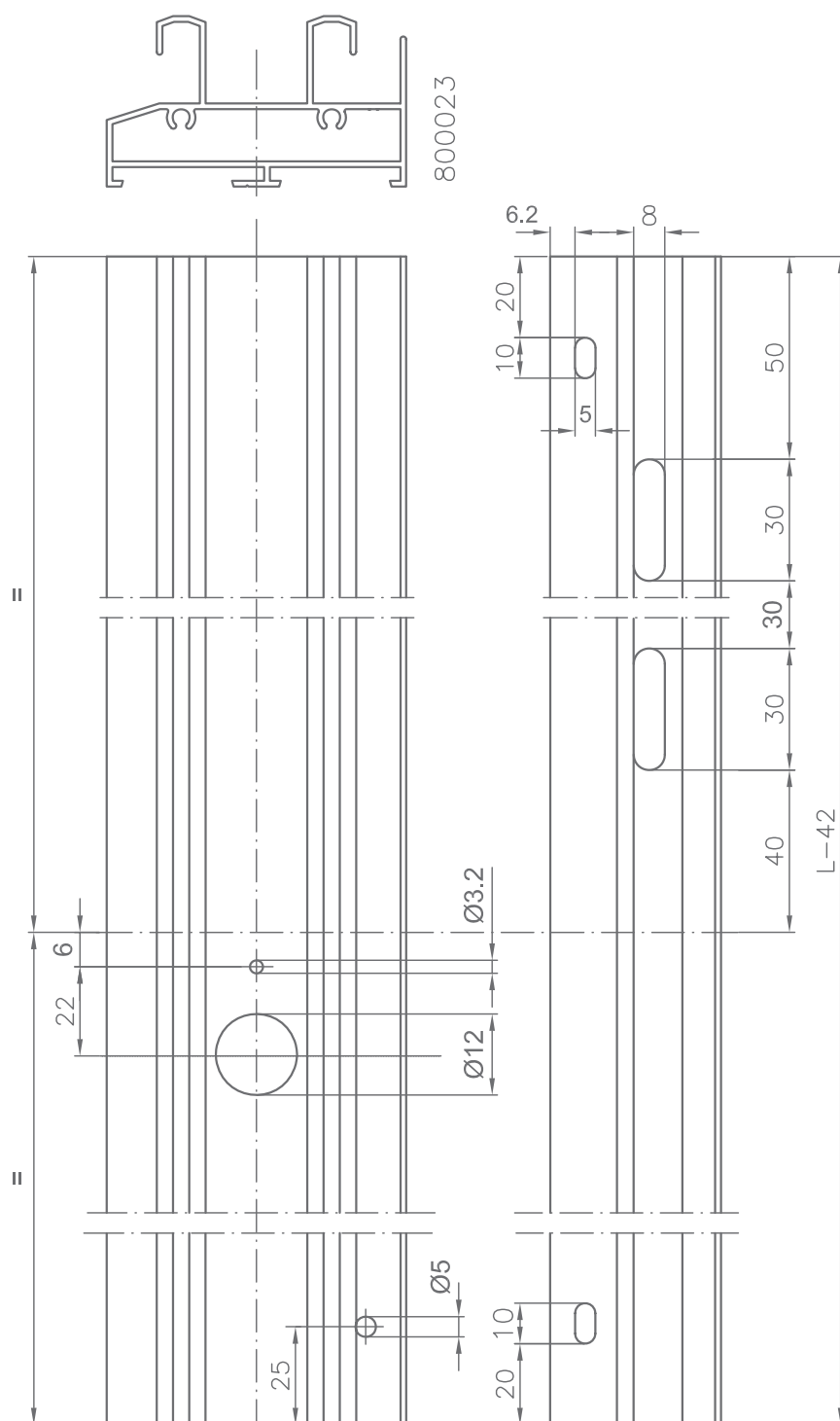

CON MARCO LATERAL

800030

800032

800033

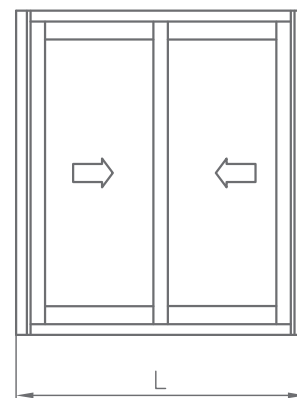



MECANIZADOS | MACHINING

Marco lateral

Lateral frame

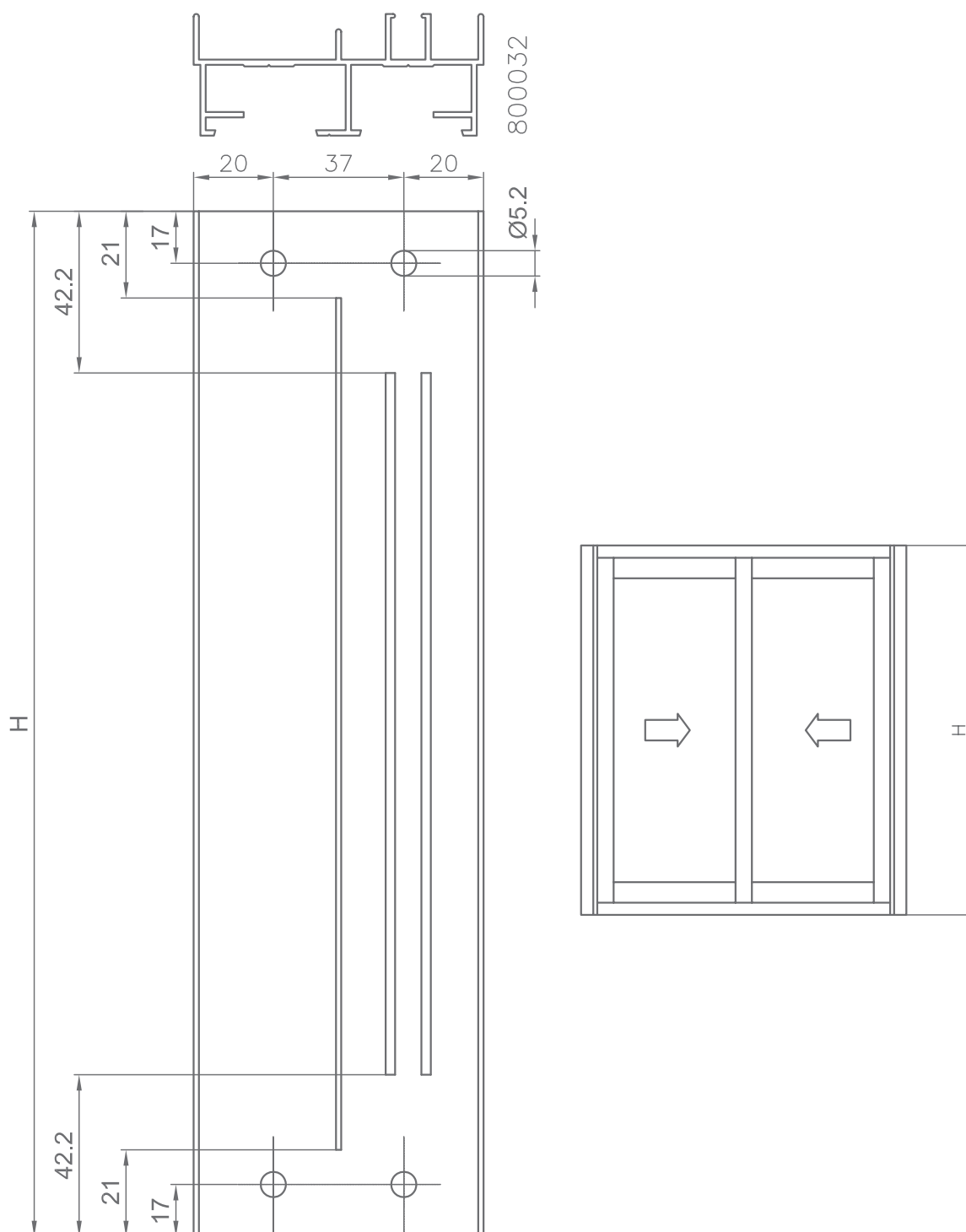



MECANIZADOS | MACHINING

Marco lateral con fijo

Lateral frame with fixed

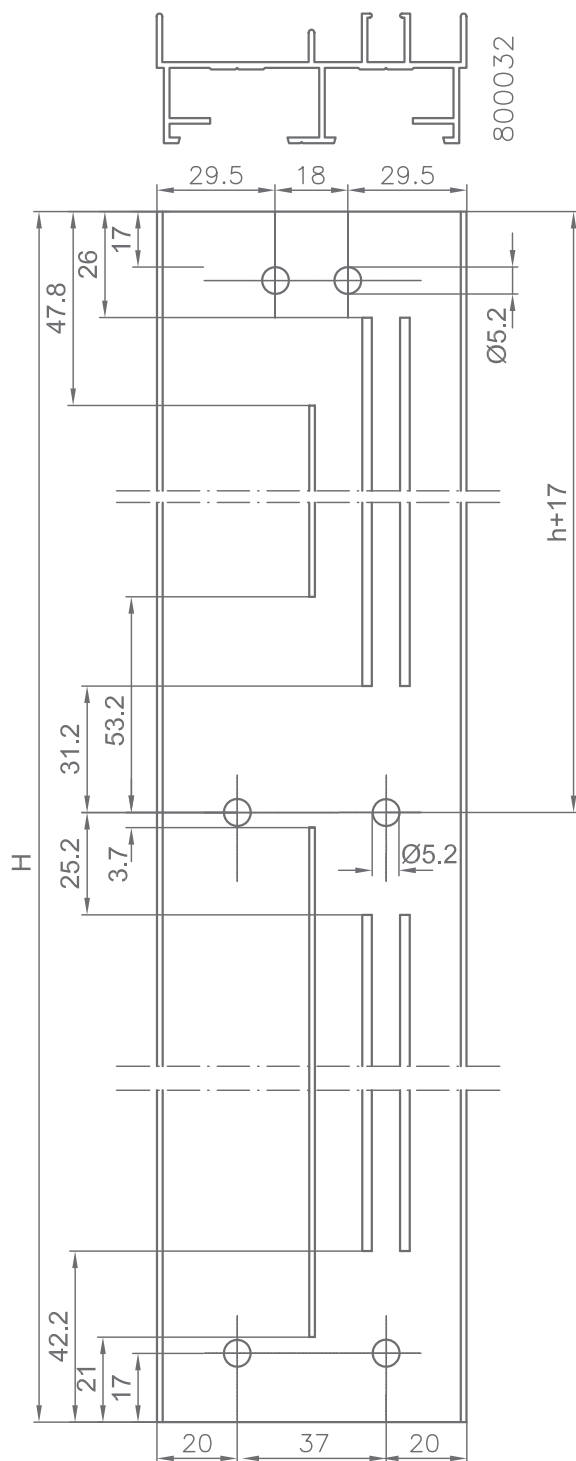

CON MARCOS
SUPERIOR 800012
INFERIOR 800022-800023
FIJO 800080-800090

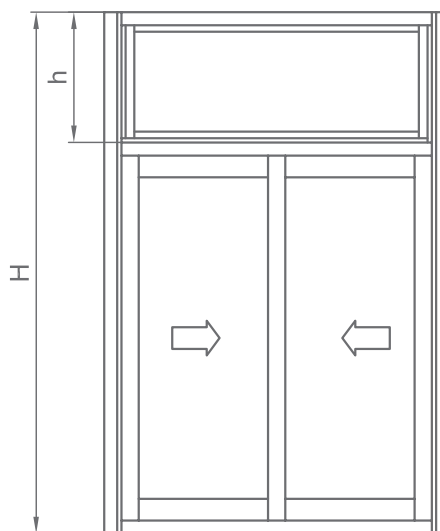



MECANIZADOS | MACHINING

Hoja lateral

Lateral sash

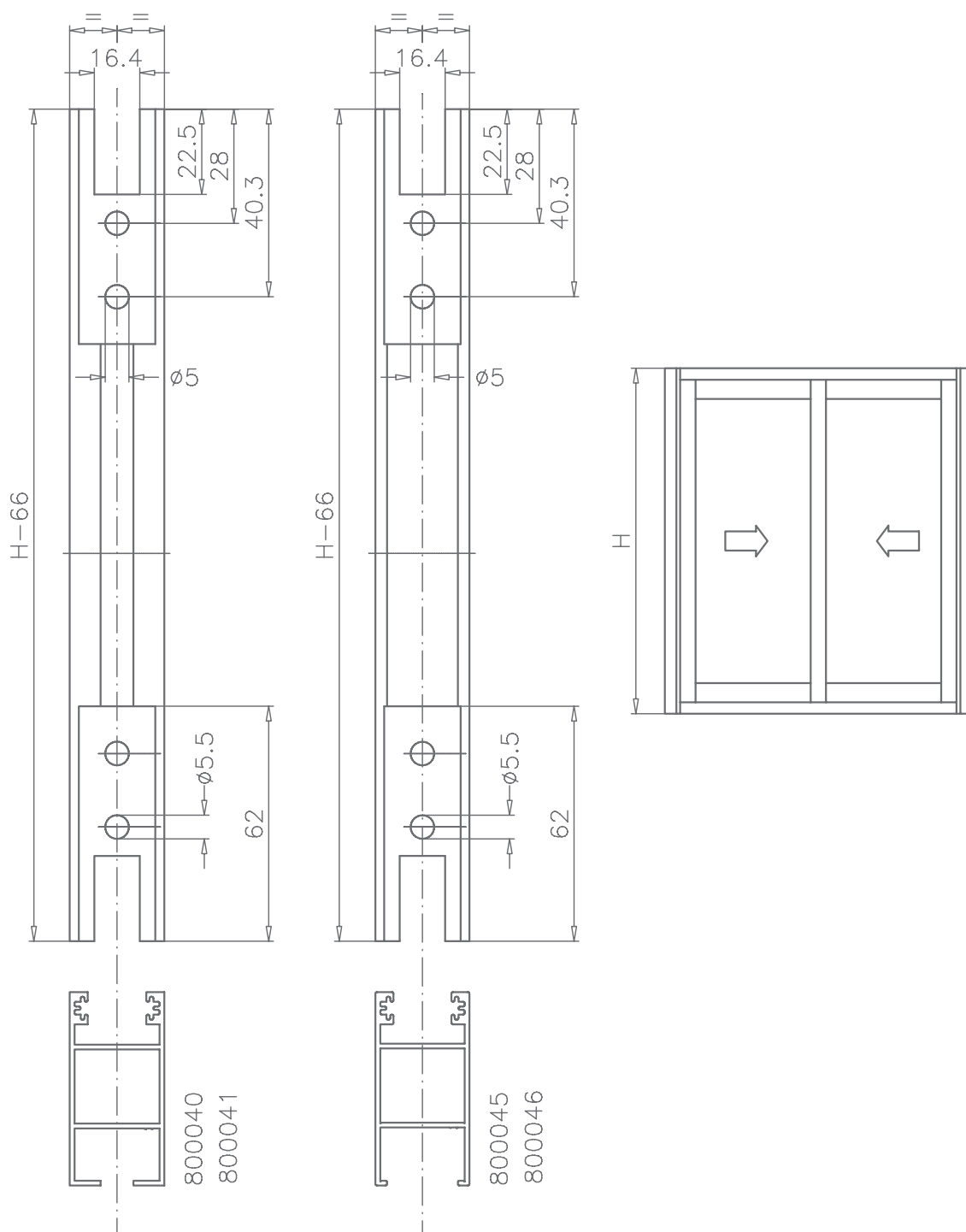



MECANIZADOS | MACHINING

Mecanizado del cierre en la hoja lateral

Lock machining on lateral sash

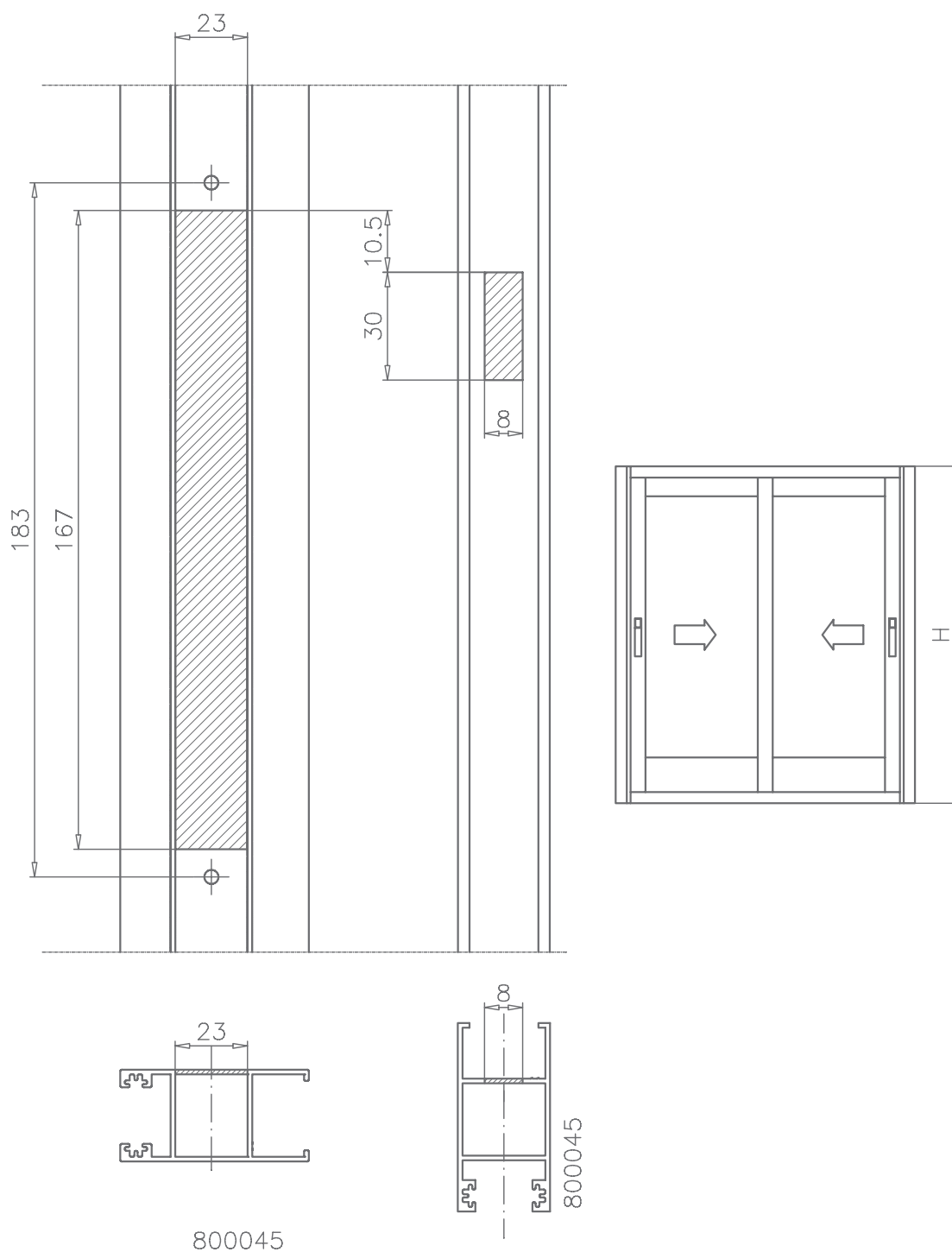



MECANIZADOS | MACHINING

Hoja central

Central sash

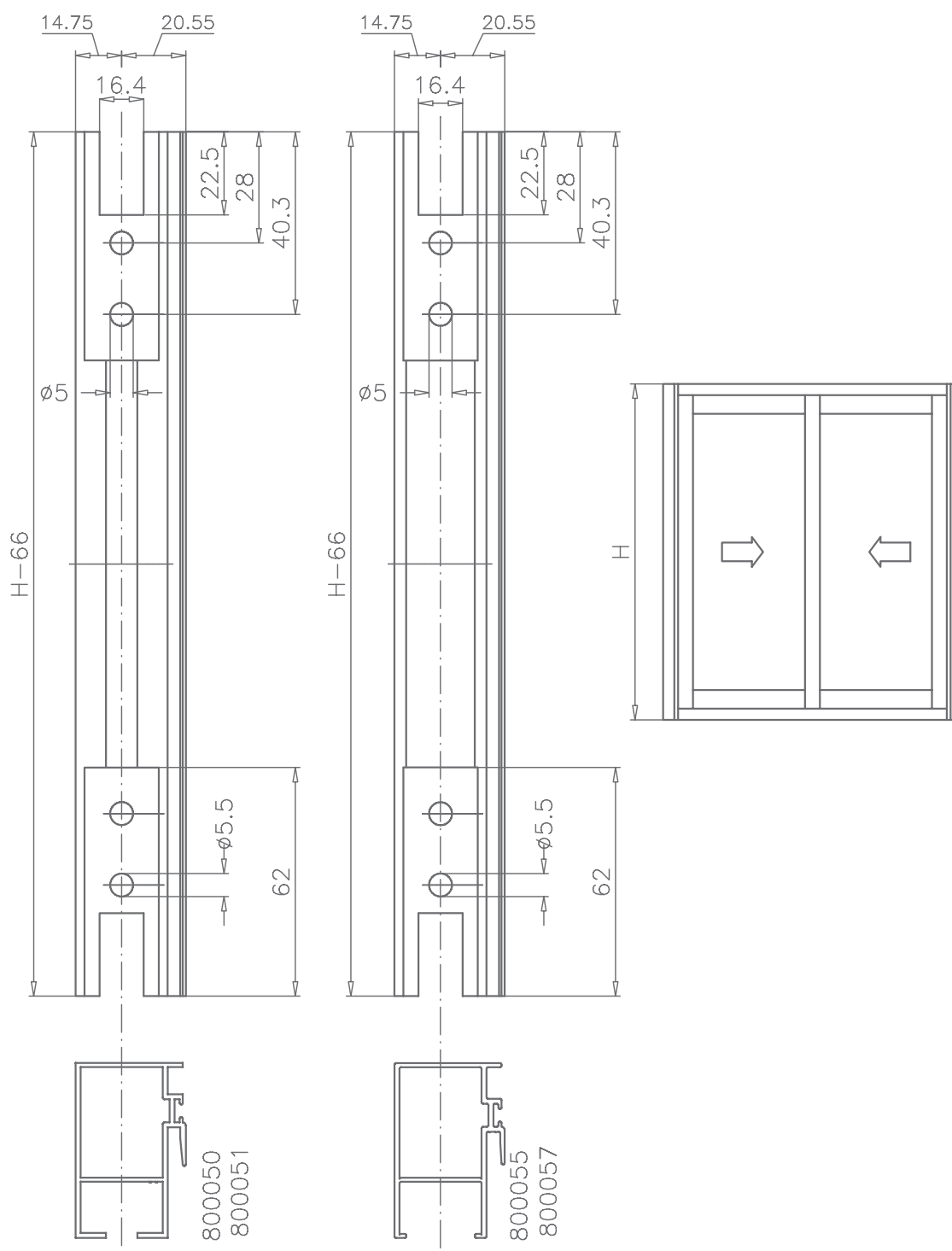



MECANIZADOS | MACHINING

Hoja horizontal, superior e inferior

Horizontal sash, superior and inferior

MARCO LATERAL

800030

800032

800033

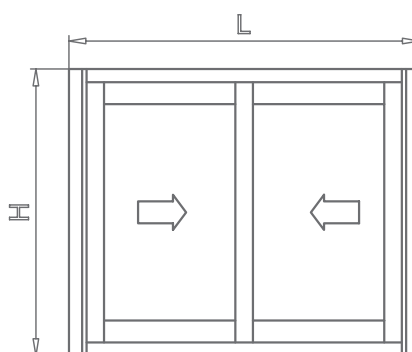

800060		
800061		
800065		
800066		
800070		
800075		
800401		
800402		
		$L/2 - 17$ (2 Hojas)
		$L/4 - 8$ (4 Hojas)
		$L/3 + 3$ (3 Hojas iguales)
		2 Hojas laterales ($L/3 - 1$) 1 Hoja central ($L/3 + 11$)

(3 Hojas mismo cristal)



MECANIZADOS | MACHINING

Mecanizado para el recogedor en marco lateral con guía
Machining for shutter casing on lateral frame with guide

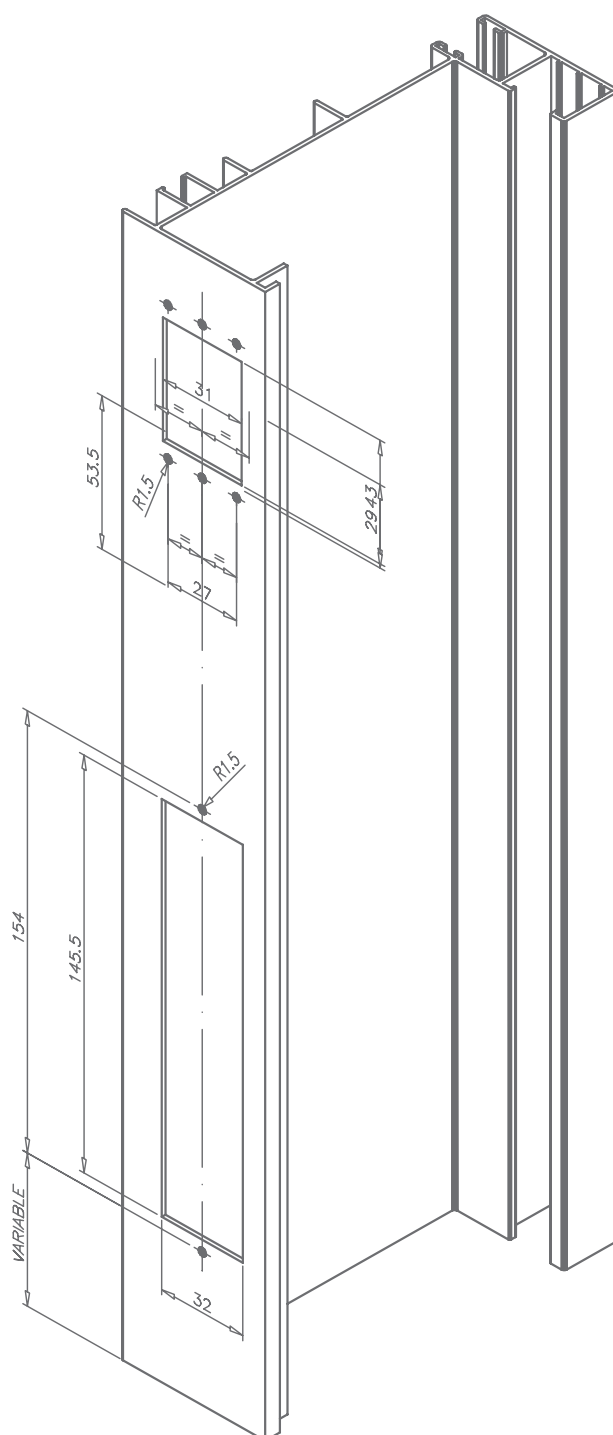



MECANIZADOS | MACHINING

Marco fijo horizontal y vertical
Horizontal and vertical fixed frame

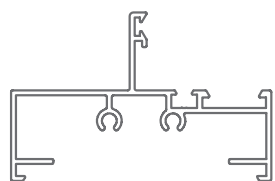

800080

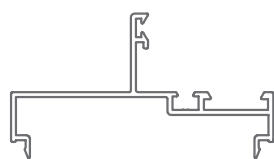

800090

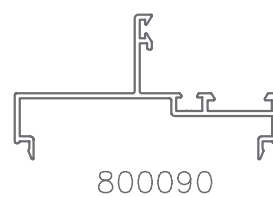
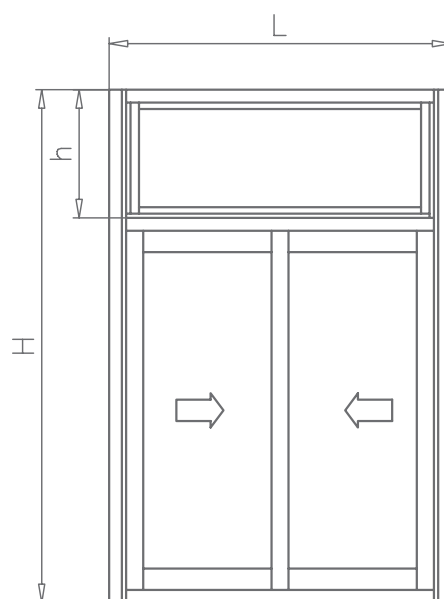
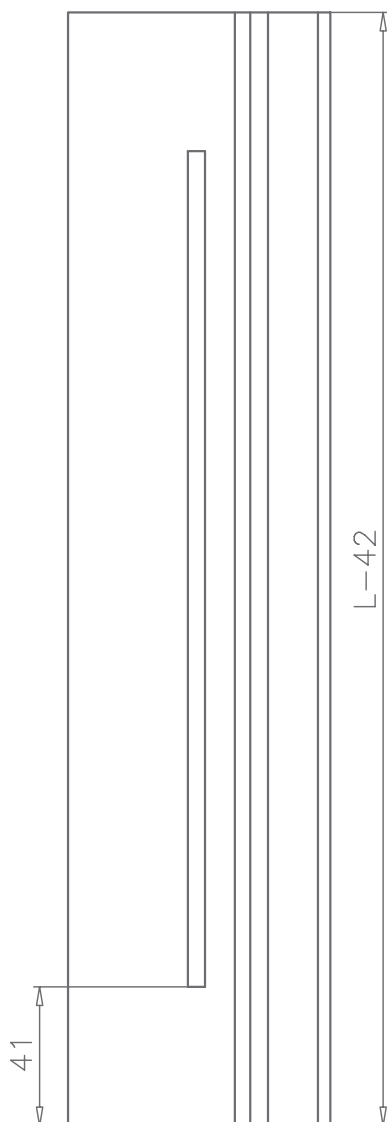
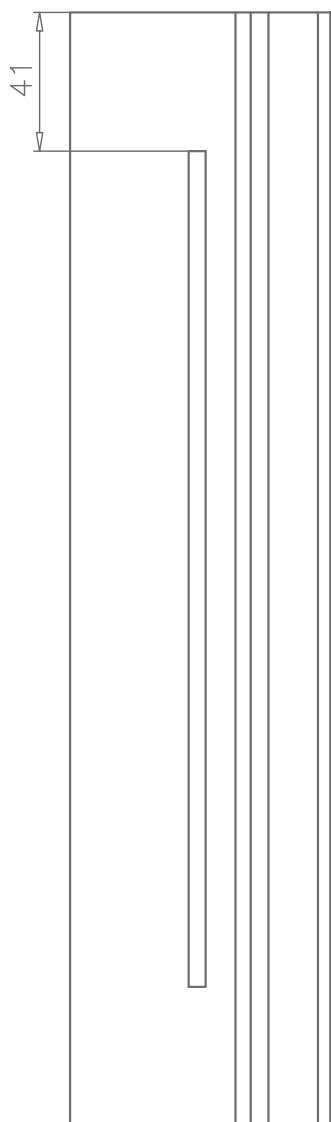

800090

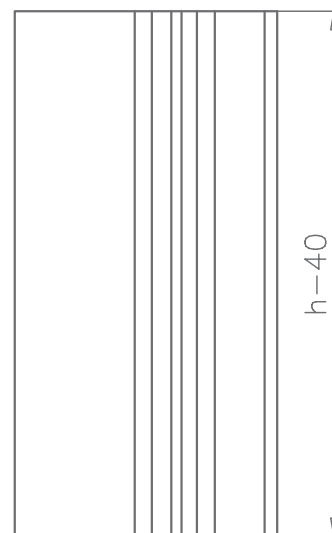



MECANIZADOS | MACHINING

Marco fijo horizontal y vertical
Horizontal and vertical fixed frame

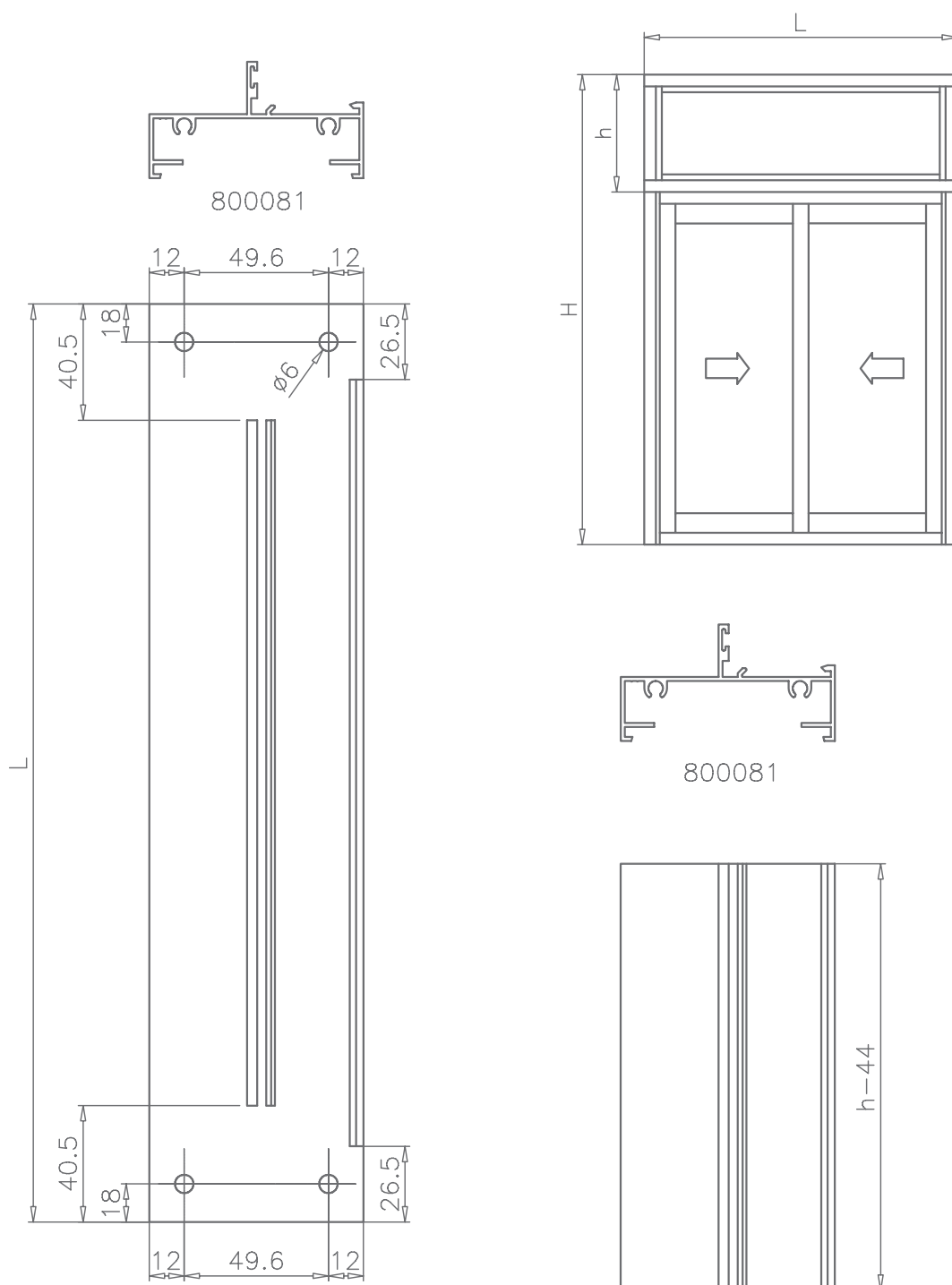



HIERROS
JATIVA

SERIE 800

CORREDERA DE CORTE RECTO
STRAIGHT CUT SLIDING

MECANIZADOS | MACHINING

Marco superior

Superior frame

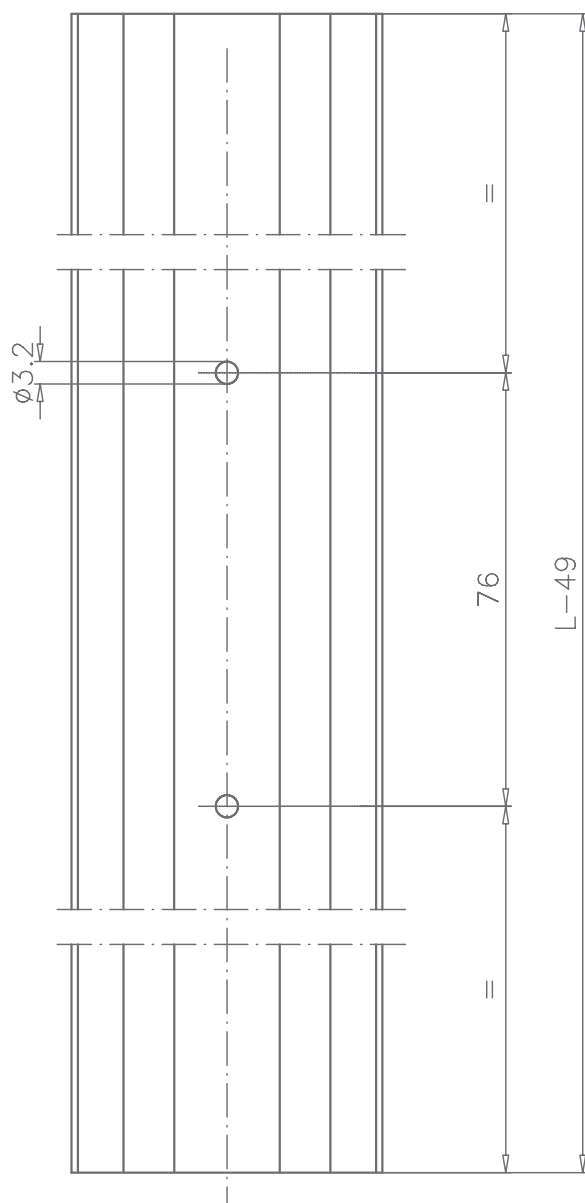
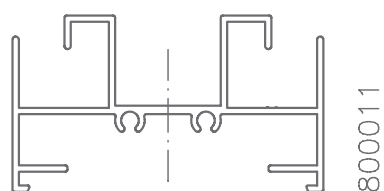

CON MARCO LATERAL
800031

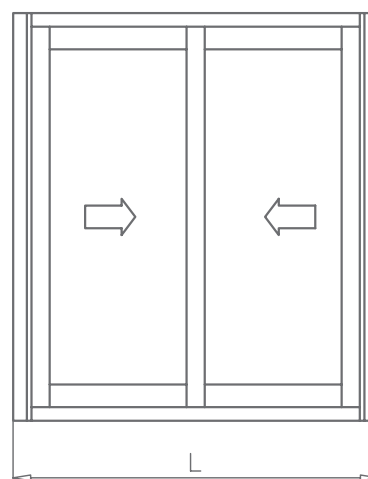



MECANIZADOS | MACHINING

Marco inferior

Inferior frame

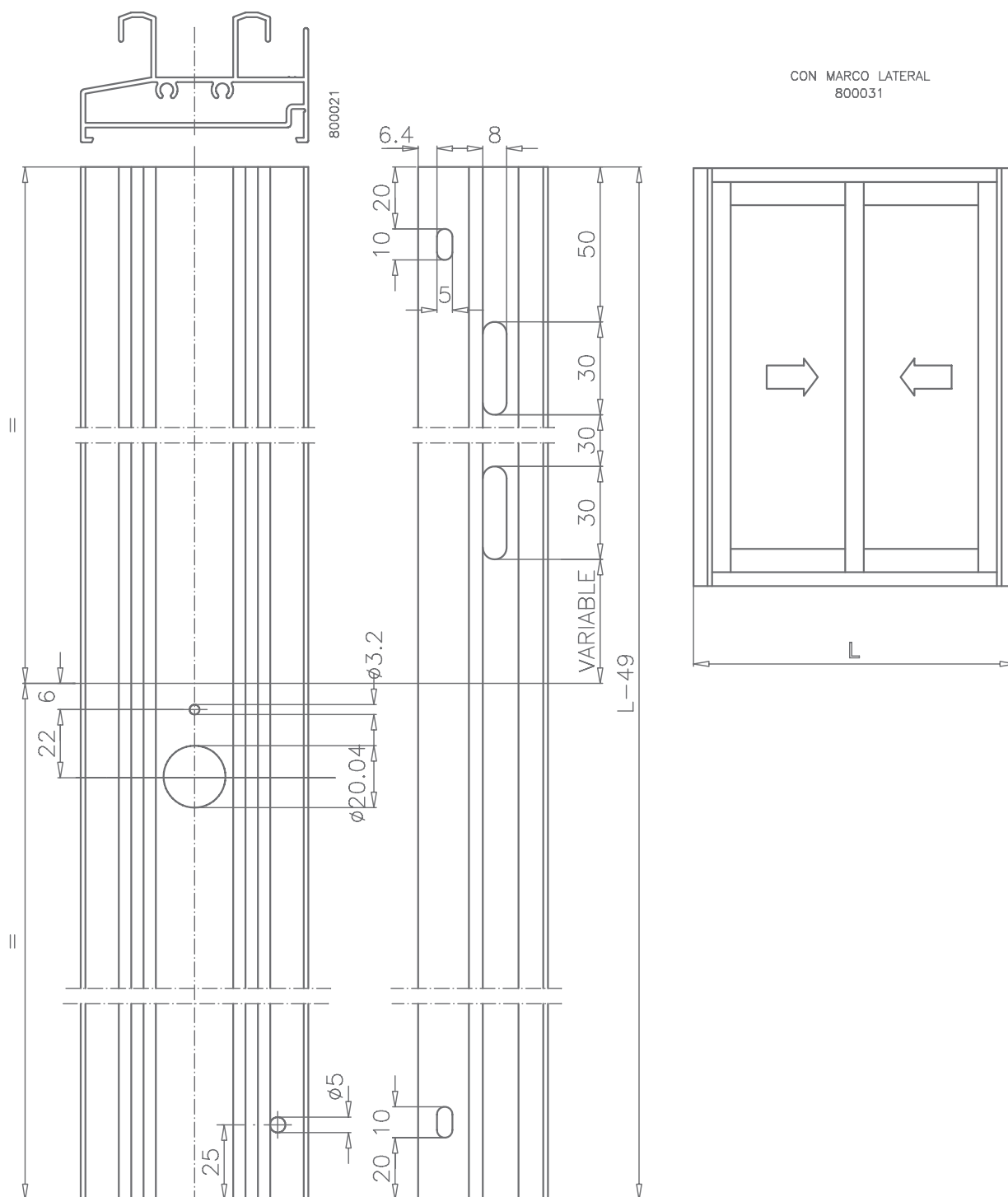



MECANIZADOS | MACHINING

Marco lateral

Lateral frame

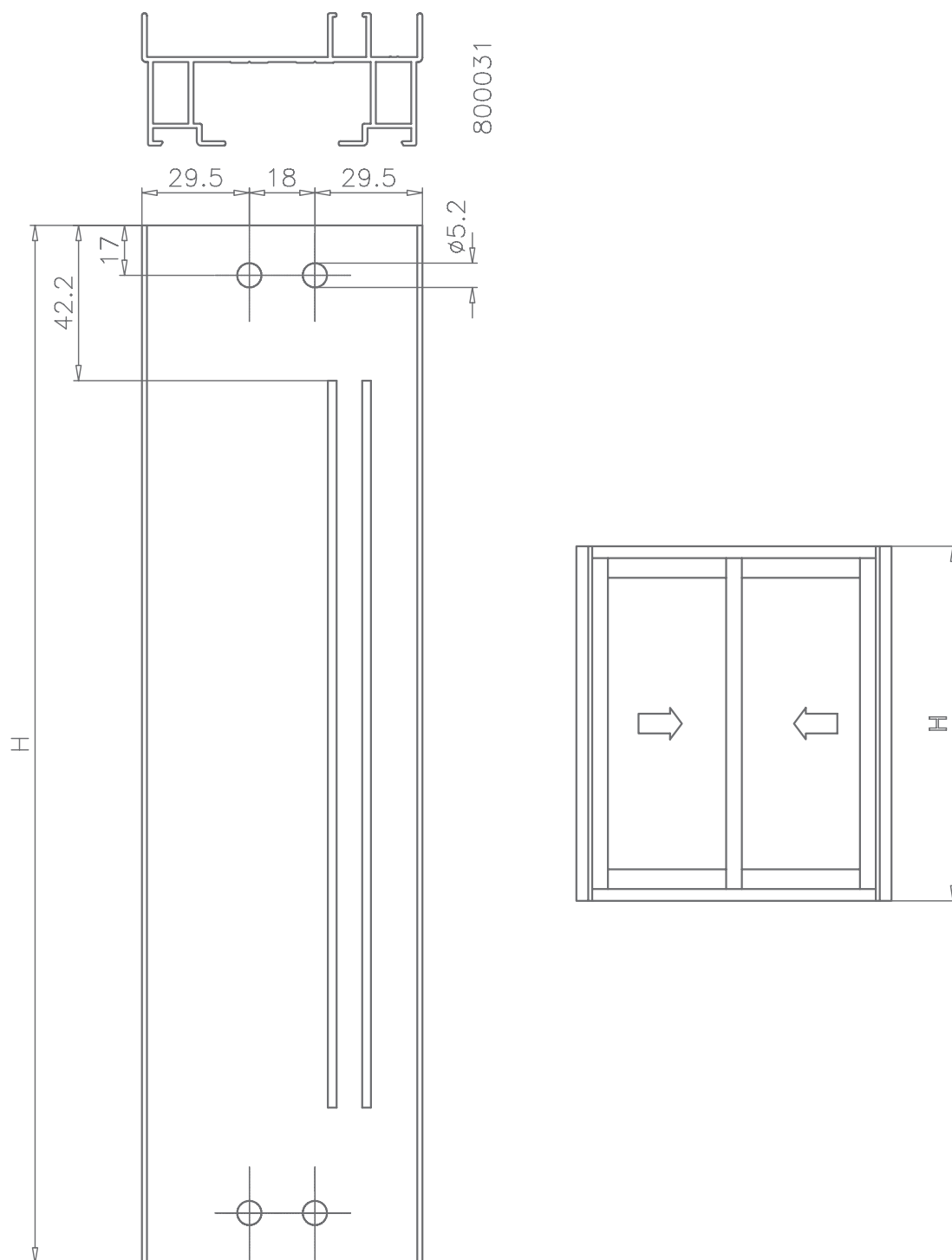



MECANIZADOS | MACHINING

Marco lateral

Lateral frame

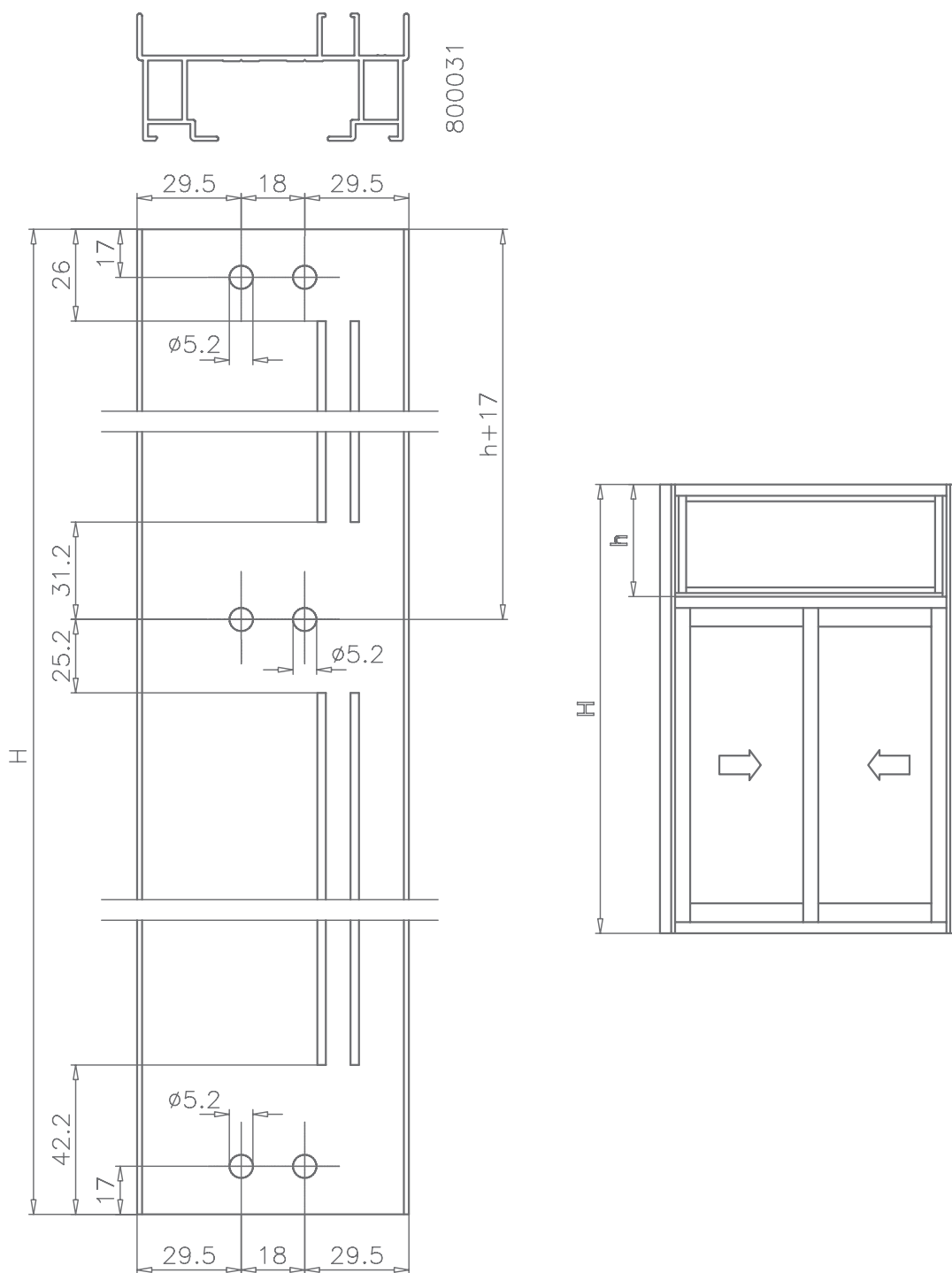



MECANIZADOS | MACHINING

Hoja horizontal, superior e inferior
Horizontal sash, superior and inferior

MARCO LATERAL
800031

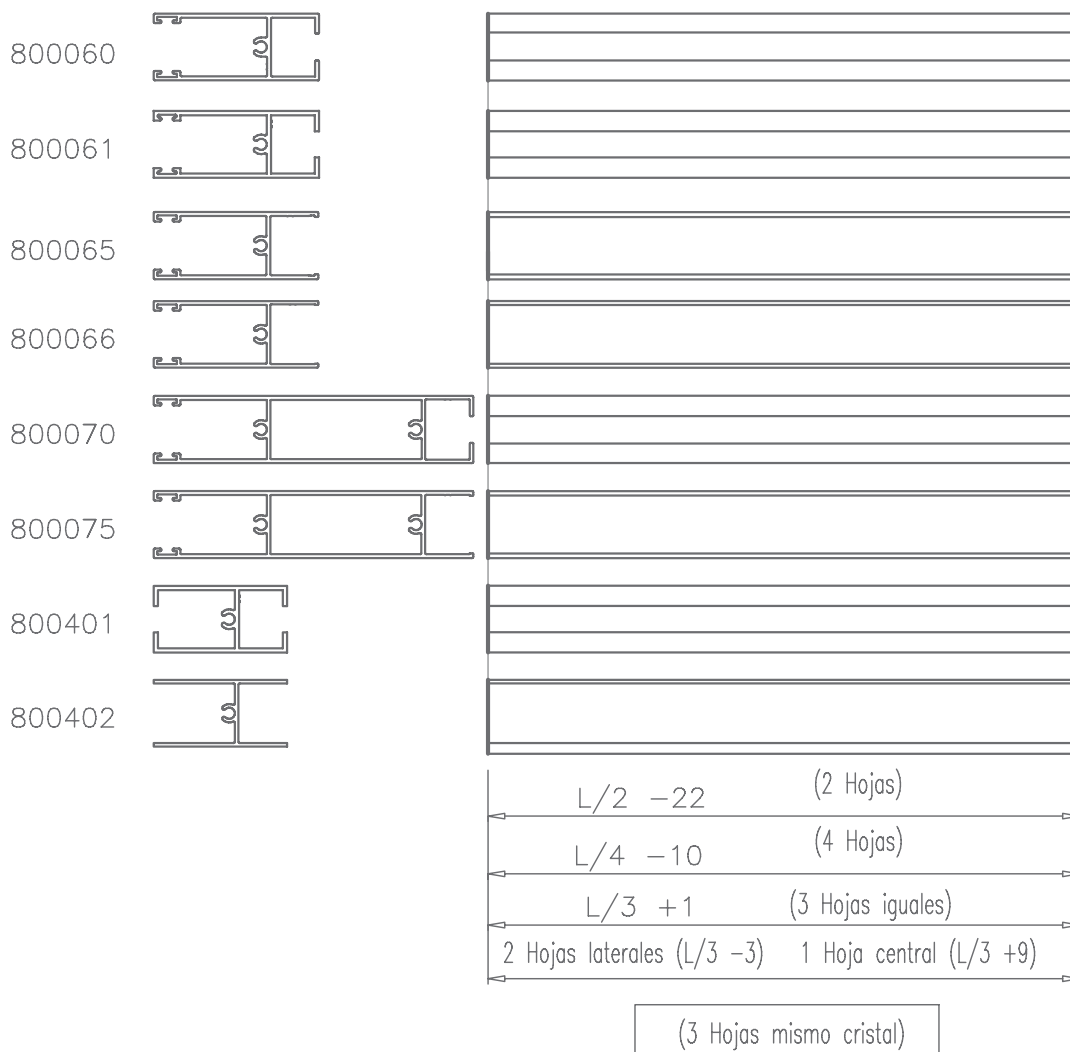
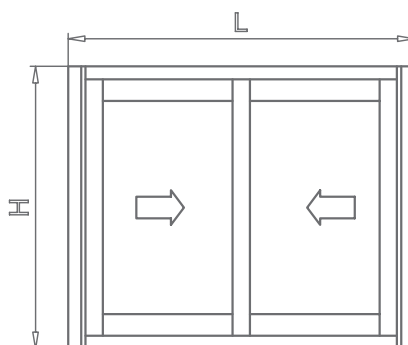



**HIERROS
JÁTIVA**

CENTRAL

Pol.Ind. "La Vila" Parcela 5.
46819 / Novetlé / Valencia (Spain)
administracion@hierrosjativa.com

Tel.: 96 227 08 00
Fax.: 96 227 41 63
HIERRO: 678 255 770
ALUMINIO: 678 252 153

.....

DELEGACIÓN ALICANTE

Pol.Ind. I-8, Calle Catral
033330 / Crevillente / Alicante (Spain)
crevillente@hierrosjativa.com

Tel.: 96 540 45 61
Fax.: 96 540 46 45

.....

DELEGACIÓN ZARAGOZA

Alfredo Abad

alfredoberdusan@gmail.com
Tel.: 647 576 092