



CORREDERA DE CORTE RECTO  
STRAIGHT CUT SLIDING  
Serie 2300

**CORTE | MECANIZADO**





**ESQUEMAS DE CORTE | CUTTING SCHEMES**

Corte de dos carriles con fijo independiente

Two ways cutting with fixed independent

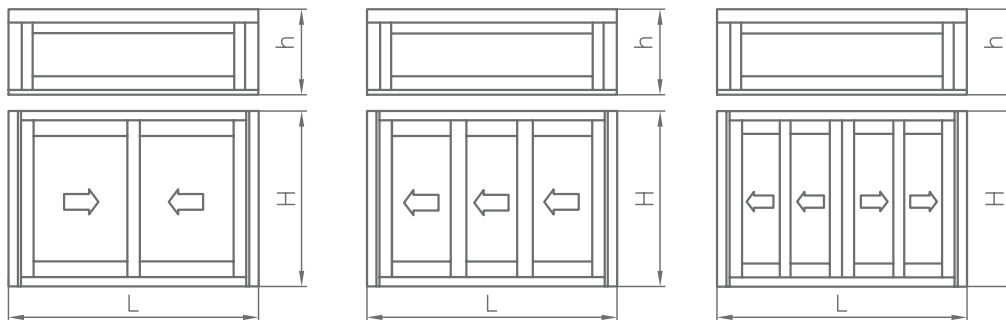

PERFILES – LONGITUDES DE CORTE								
PERFIL	FIGURA	DESCRIPCION	2 HOJAS		3 HOJAS		4 HOJAS	
			CANT.	CORTE	CANT.	CORTE	CANT.	CORTE
230010		MARCO SUPERIOR	1	L-31	1	L-31	1	L-31
230020		MARCO INFERIOR	1	L-31	1	L-31	1	L-31
230030		MARCO LATERAL	2	H	2	H	2	H
230040		HOJA LATERAL CAMARA 10	2	H-48	2	H-48	4	H-48
230045		HOJA LATERAL CAMARA 18.4	2	H-48	2	H-48	4	H-48
230050		HOJA CENTRAL CAMARA 10	2	H-48	4	H-48	4	H-48
230055		HOJA CENTRAL CAMARA 18.4	2	H-48	4	H-48	4	H-48
230060		HOJA DE RUEDA CAMARA 10	4	L/2 -18	6	L/3 +1	8	L/4 -9
230065		HOJA DE RUEDA CAMARA 18.4	4	L/2 -18	6	L/3 +1	8	L/4 -9
230070		ZOCALO CAMARA 10	2	L/2 -18	3	L/3 +1	4	L/4 -9
230075		ZOCALO CAMARA 18.4	2	L/2 -18	3	L/3 +1	4	L/4 -9
230080		MARCO FIJO SIN CLIP	2	h-33.6	2	h-33.6	2	h-33.6
230080		MARCO FIJO SIN CLIP	1	L	1	L	1	L
230090		MARCO FIJO CON CLIP	1	L	1	L	1	L
VARIOS		JUNQUILLO	2	L-43	2	L-43	2	L-43
VARIOS		JUNQUILLO	2	h-73	2	h-73	2	h-73
230081		MARCO FIJO SIN CLIP	2	h-26	2	h-26	2	h-26
230081		MARCO FIJO SIN CLIP	1	L	1	L	1	L
230091		MARCO FIJO CON CLIP	1	L	1	L	1	L
VARIOS		JUNQUILLO	2	L-41	2	L-41	2	L-41
VARIOS		JUNQUILLO	2	h-55	2	h-55	2	h-55
230401		DIVISOR CRISTAL SIMPLE	2	L/2 -12	3	L/3 +6	4	L/4 -4
700402		DIVISOR CRISTAL DOBLE	2	L/2 -12	3	L/3 +6	4	L/4 -4
700400		PERFIL 4 HOJAS					1	H-48



**ESQUEMAS DE CORTE | CUTTING SCHEMES**

Corte de dos carriles con fijo clipado

Two ways cutting with fixed clipping

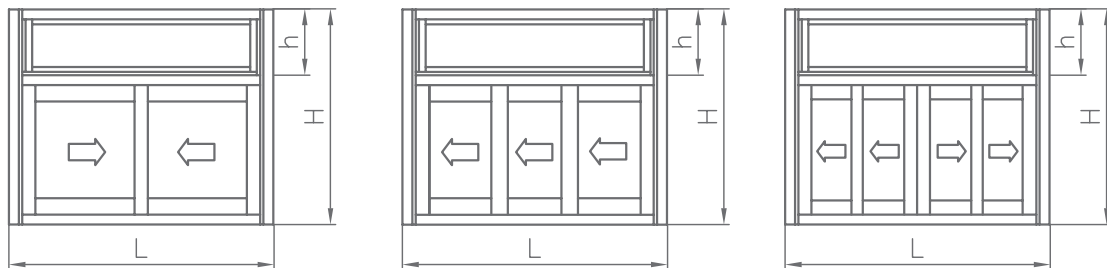

PERFILES – LONGITUDES DE CORTE								
PERFIL	FIGURA	DESCRIPCION	2 HOJAS		3 HOJAS		4 HOJAS	
			CANT.	CORTE	CANT.	CORTE	CANT.	CORTE
230010		MARCO SUPERIOR	1	L-31	1	L-31	1	L-31
230020		MARCO INFERIOR	1	L-31	1	L-31	1	L-31
230030		MARCO LATERAL	2	H	2	H	2	H
230040		HOJA LATERAL CAMARA 10	2	H-h-48	2	H-h-48	4	H-h-48
230045		HOJA LATERAL CAMARA 18.4	2	H-h-48	2	H-h-48	4	H-h-48
230050		HOJA CENTRAL CAMARA 10	2	H-h-48	4	H-h-48	4	H-h-48
230055		HOJA CENTRAL CAMARA 18.4	2	H-h-48	4	H-h-48	4	H-h-48
230060		HOJA DE RUEDA CAMARA 10	4	L/2-18	6	L/3+1	8	L/4-9
230065		HOJA DE RUEDA CAMARA 18.4	4	L/2-18	6	L/3+1	8	L/4-9
230070		ZOCALO CAMARA 10	2	L/2-18	3	L/3+1	4	L/4-9
230075		ZOCALO CAMARA 18.4	2	L/2-18	3	L/3+1	4	L/4-9
230080		MARCO FIJO SIN CLIP	2	h-33.6	2	h-33.6	2	h-33.6
230080		MARCO FIJO SIN CLIP	1	L	1	L	1	L
230090		MARCO FIJO CON CLIP	1	L	1	L	1	L
VARIOS		JUNQUILLO	2	L-74	2	L-74	2	L-74
VARIOS		JUNQUILLO	2	h-73	2	h-73	2	h-73
230081		MARCO FIJO SIN CLIP	2	h-26	2	h-26	2	h-26
230081		MARCO FIJO SIN CLIP	1	L	1	L	1	L
230091		MARCO FIJO CON CLIP	1	L	1	L	1	L
VARIOS		JUNQUILLO	2	L-71	2	L-71	2	L-71
VARIOS		JUNQUILLO	2	h-55	2	h-55	2	h-55
230401		DIVISOR CRISTAL SIMPLE	2	L/2-12	3	L/3+6	4	L/4-4
700402		DIVISOR CRISTAL DOBLE	2	L/2-12	3	L/3+6	4	L/4-4
700400		PERFIL 4 HOJAS					1	H-h-48



**ESQUEMAS DE CORTE | CUTTING SCHEMES**

Corte de tres carriles con fijo independiente

Three ways cutting with fixed independent

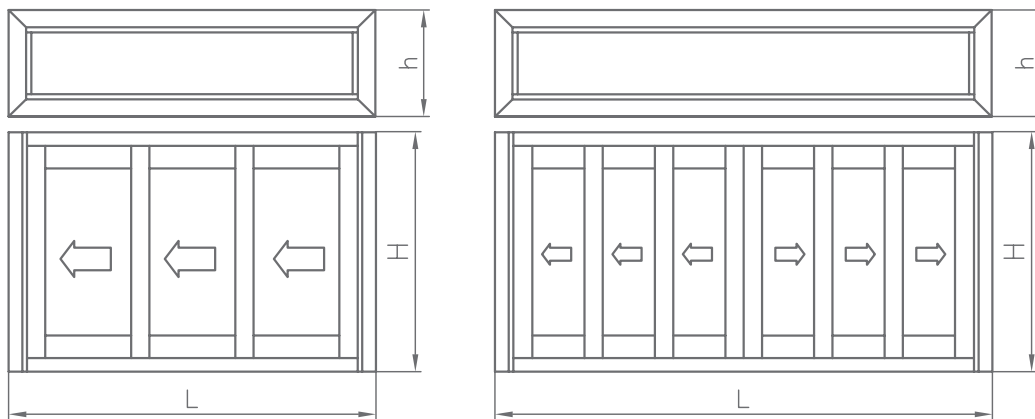

PERFILES – LONGITUDES DE CORTE						
PERFIL	FIGURA	DESCRIPCION	3 HOJAS		6 HOJAS	
			CANT.	CORTE	CANT.	CORTE
230040		HOJA LATERAL CAMARA 10	2	H-48	4	H-48
230045		HOJA LATERAL CAMARA 18.4	2	H-48	4	H-48
230050		HOJA CENTRAL CAMARA 10	4	H-48	8	H-48
230055		HOJA CENTRAL CAMARA 18.4	4	H-48	8	H-48
230060		HOJA DE RUEDA CAMARA 10	6	L/3 +1	12	L/6 +7
230065		HOJA DE RUEDA CAMARA 18.4	6	L/3 +1	12	L/6 +7
230070		ZOCALO CAMARA 10	3	L/3 +1	6	L/6 +7
230075		ZOCALO CAMARA 18.4	3	L/3 +1	6	L/6 +7
230310		MARCO SUPERIOR TRES CARRILES	1	L-31	1	L-31
230320		MARCO INFERIOR TRES CARRILES	1	L-31	1	L-31
230330		MARCO LATERAL TRES CARRILES	2	H	2	H
10080		MARCO FIJO	2	L	2	L
10080		MARCO FIJO	2	h	2	h
VARIOS		JUNQUILLO	2	L-52	2	L-52
VARIOS		JUNQUILLO	2	h-91	2	h-91
700400		PERFIL 4 HOJAS			1	H -h -48
230401		DIVISOR CRISTAL SIMPLE	3	L/3 +6	6	L/6 +12
700402		DIVISOR CRISTAL DOBLE	3	L/3 +6	6	L/6 +12



**HIERROS  
JÁTIVA**

**SERIE 2300**  
**CORREDERA DE CORTE RECTO**  
**STRAIGHT CUT SLIDING**

MECANIZADOS | MACHINING

Marco superior

Superior frame

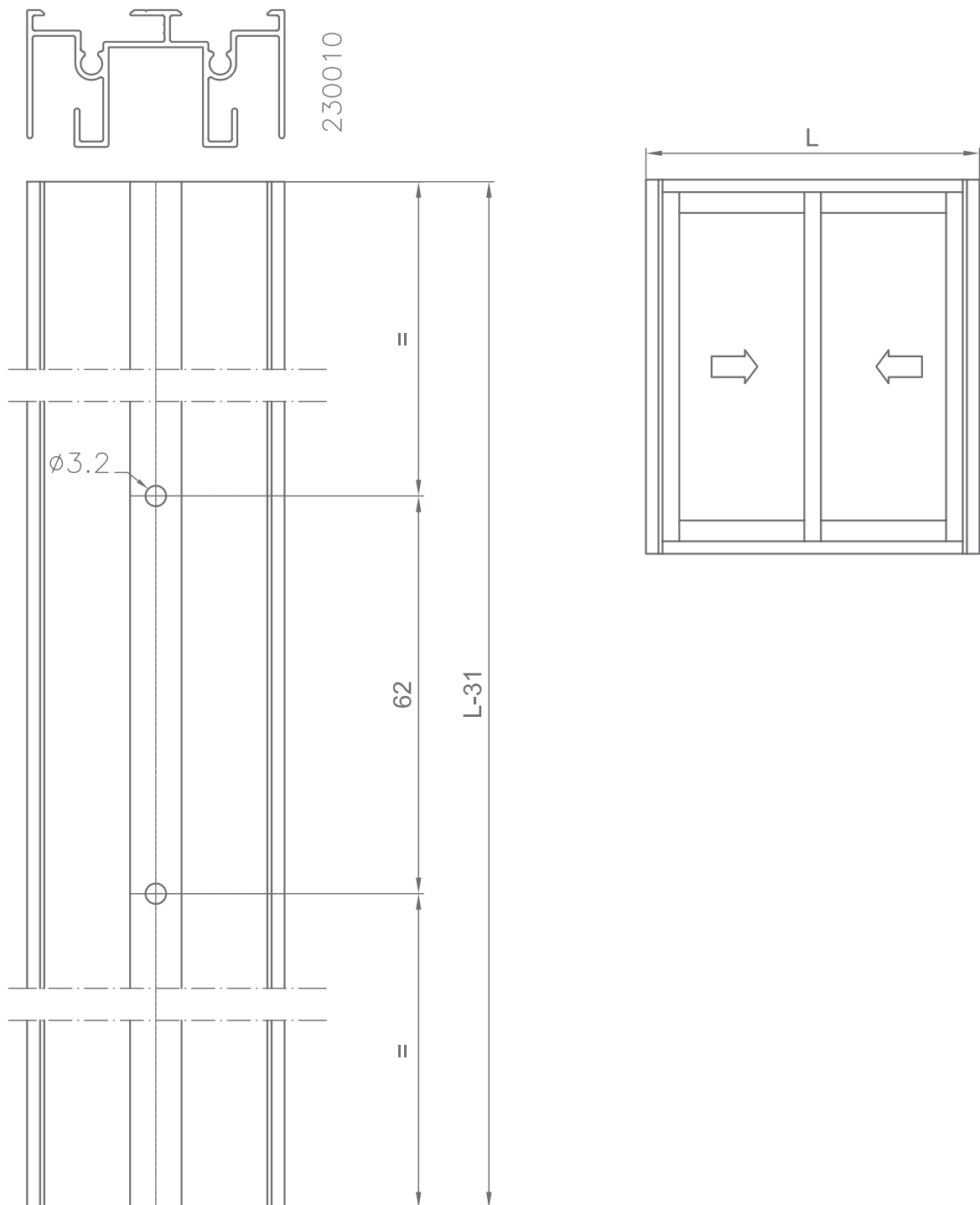



HIERROS  
JATIVA

# SERIE 2300

## CORREDERA DE CORTE RECTO STRAIGHT CUT SLIDING

MECANIZADOS | MACHINING

Marco inferior

Inferior frame

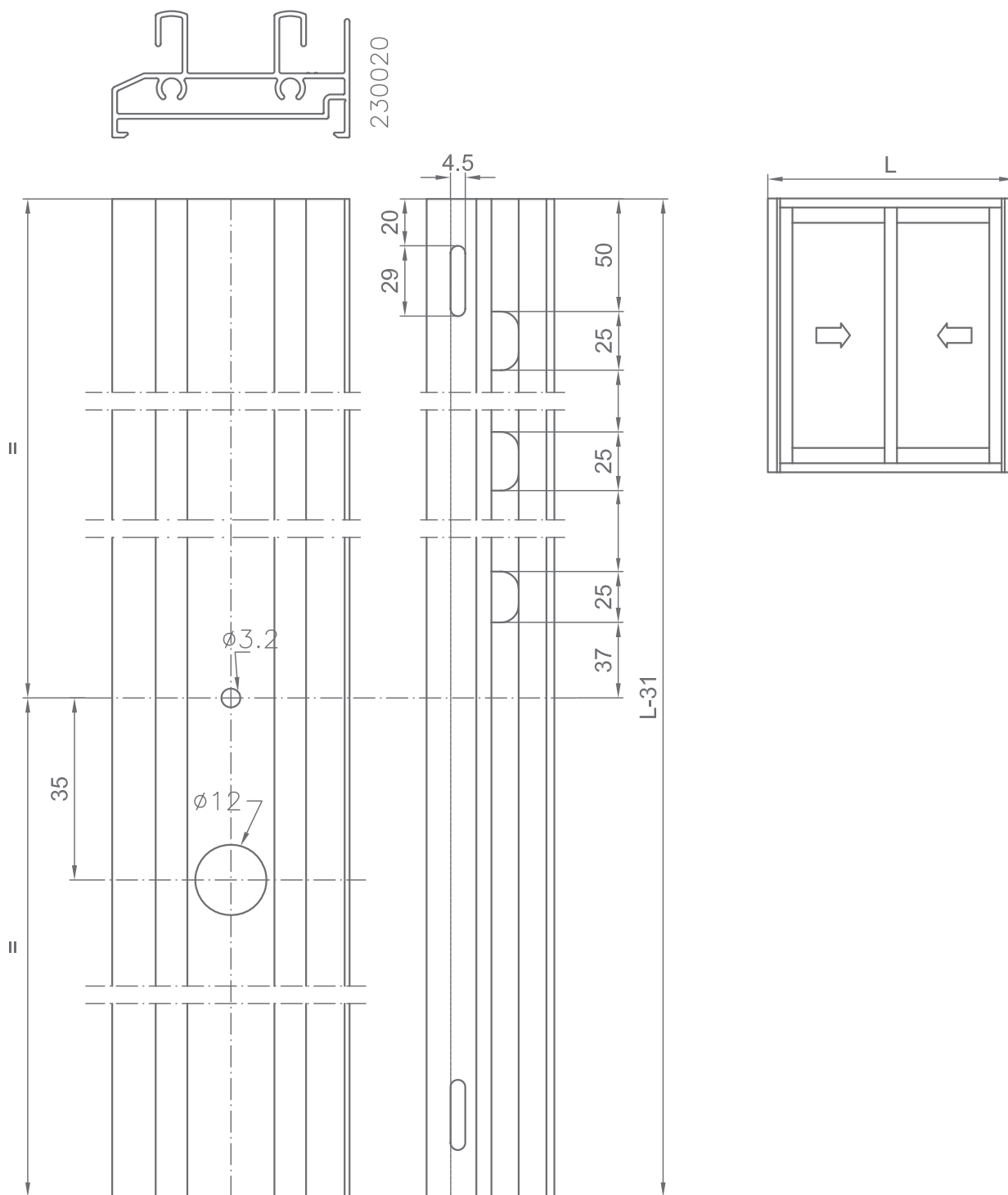



MECANIZADOS | MACHINING

Marco lateral

Lateral frame

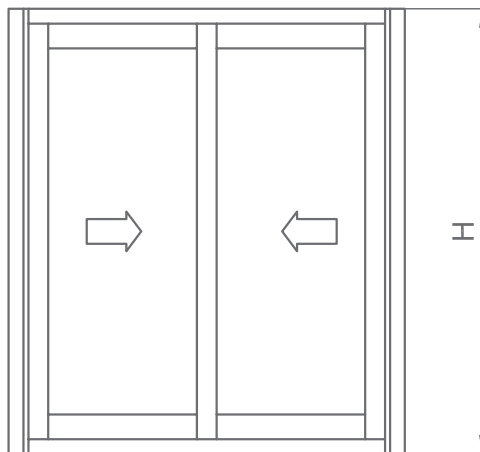
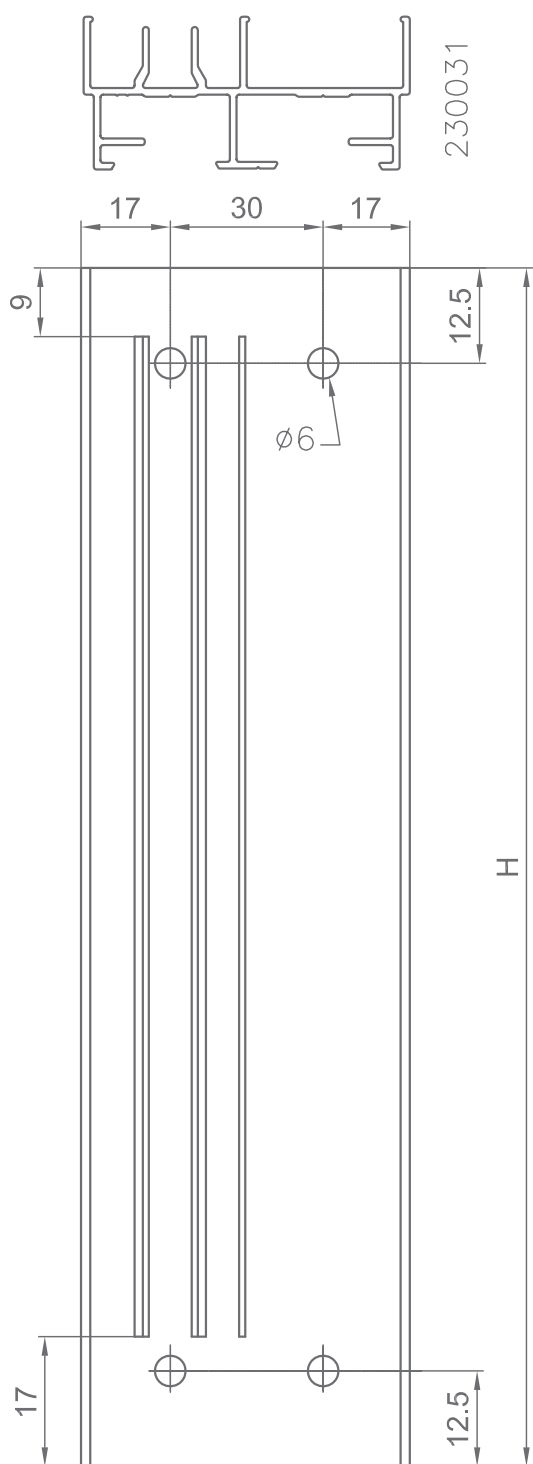



MECANIZADOS | MACHINING

Marco lateral con fijo  
Lateral frame with fixed

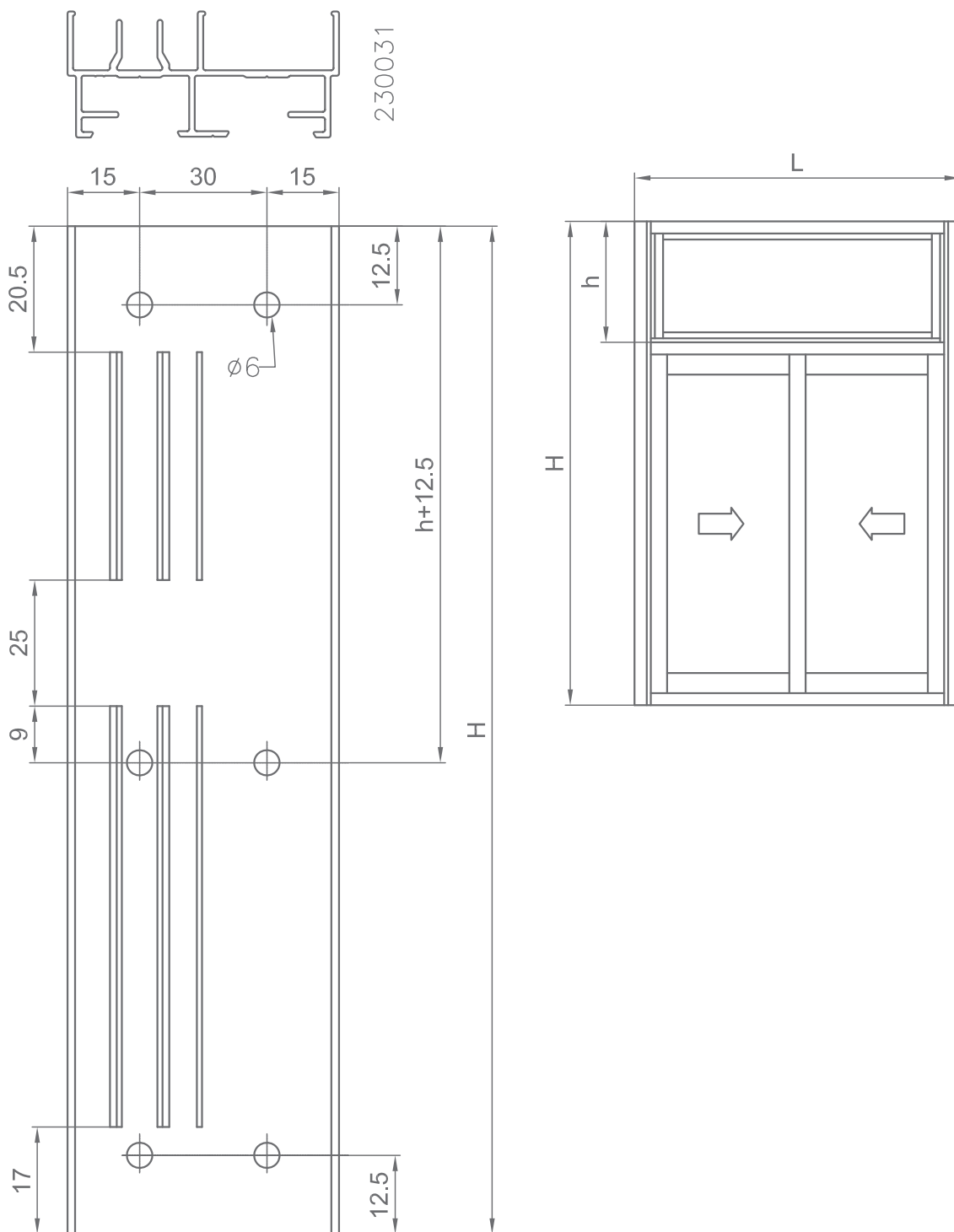





**HIERROS  
JÁTIVA**

# SERIE 2300

## CORREDERA DE CORTE RECTO STRAIGHT CUT SLIDING

MECANIZADOS | MACHINING

Marco superior tres carriles

Superior frame three ways

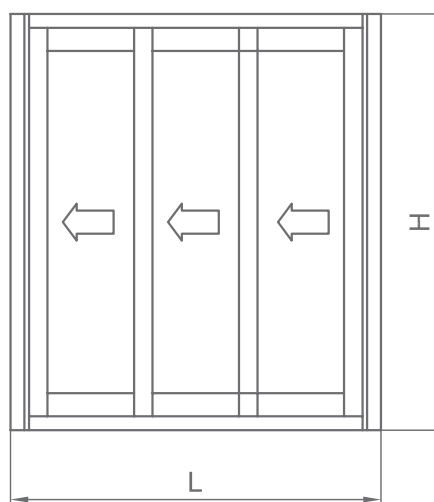
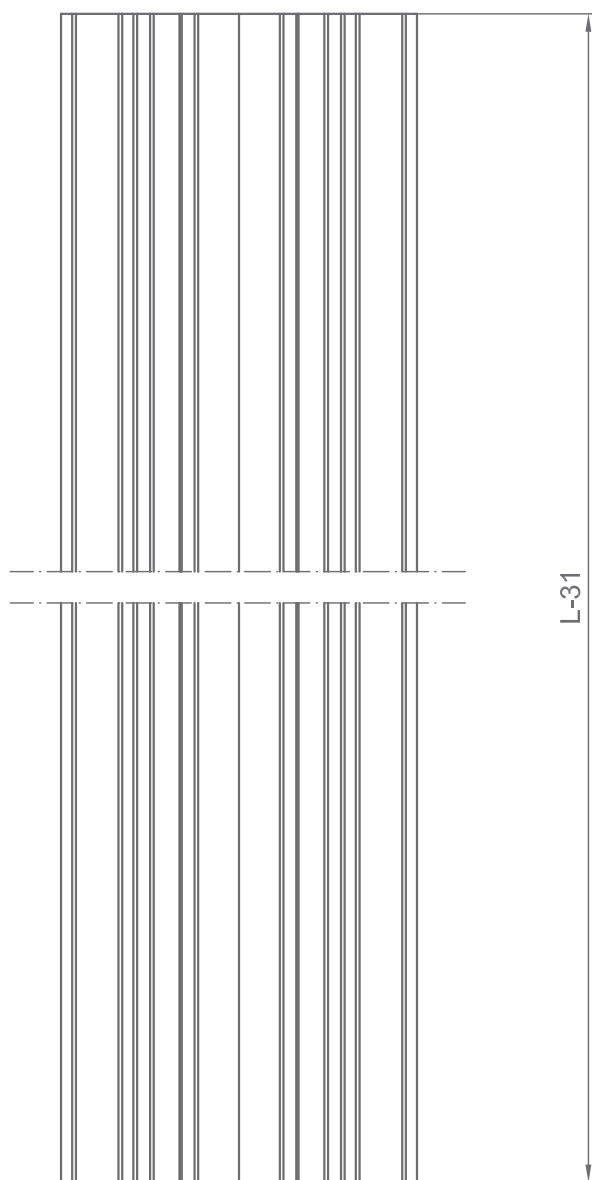



MECANIZADOS | MACHINING

Marco inferior tres carriles

Inferior frame three ways

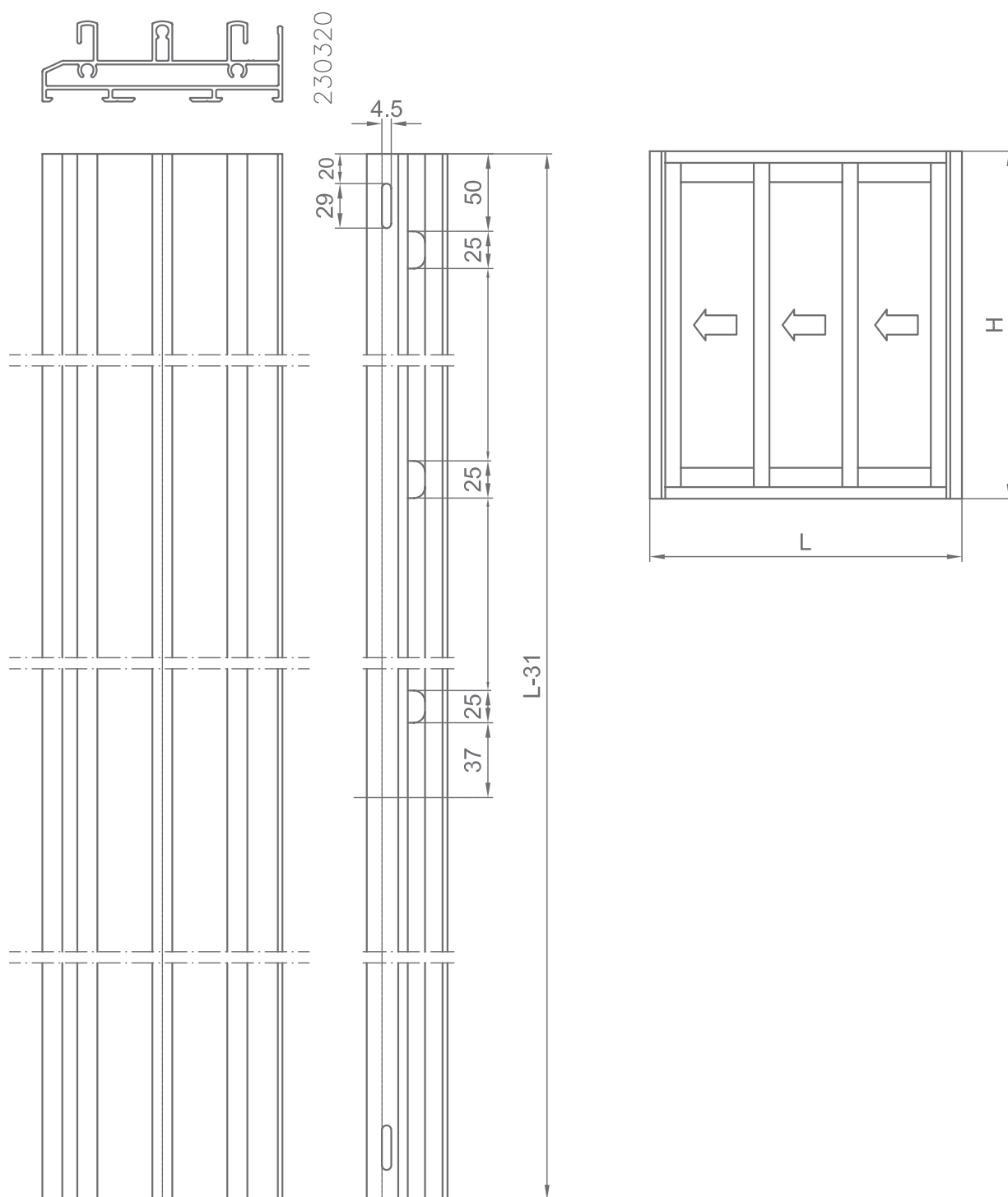



MECANIZADOS | MACHINING

Marco lateral tres carriles

Lateral frame three ways

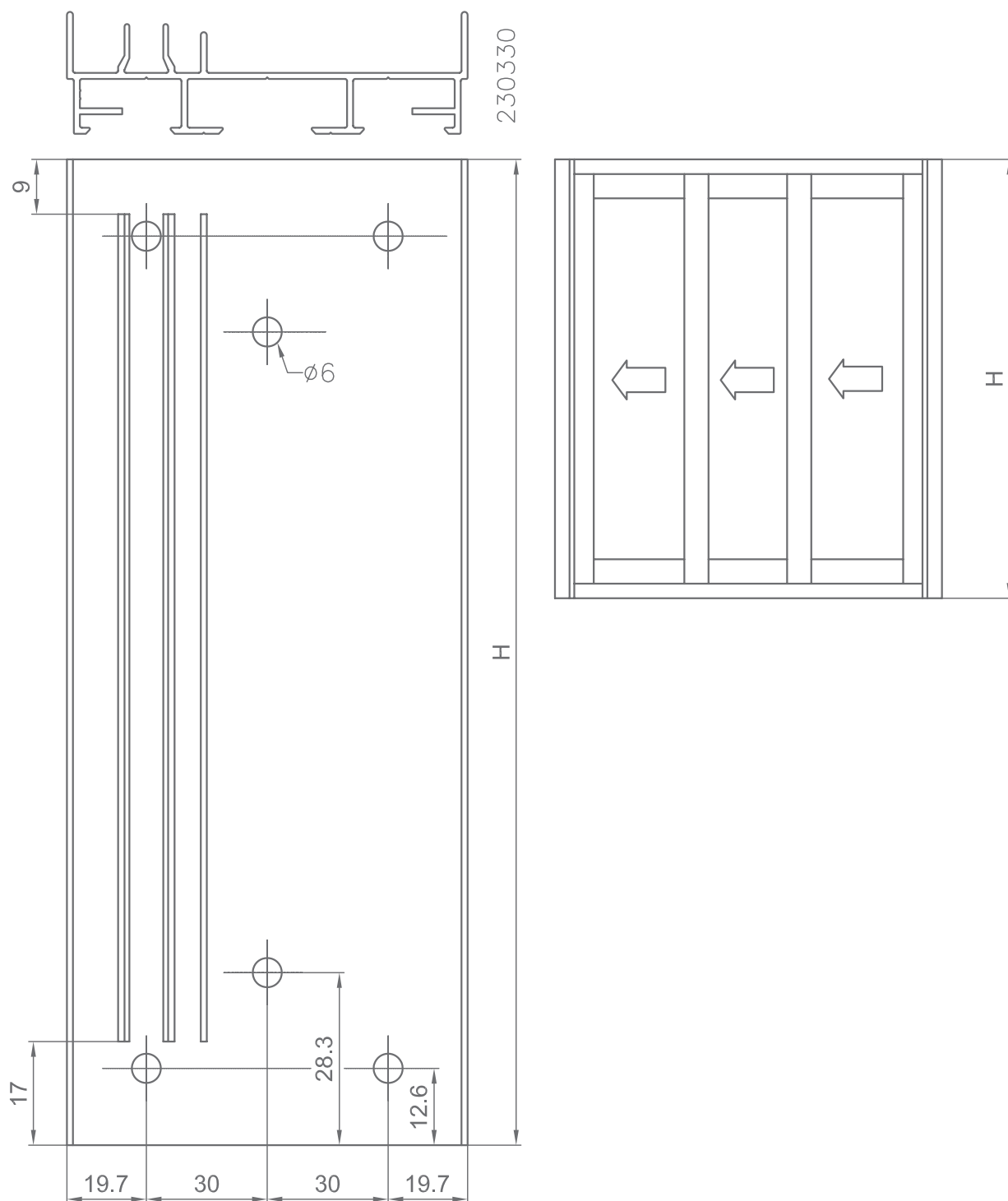



MECANIZADOS | MACHINING

Hoja lateral

Lateral sash

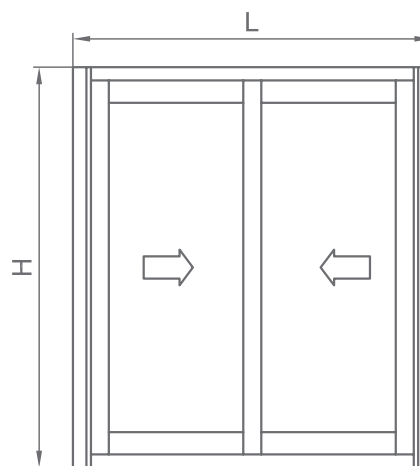
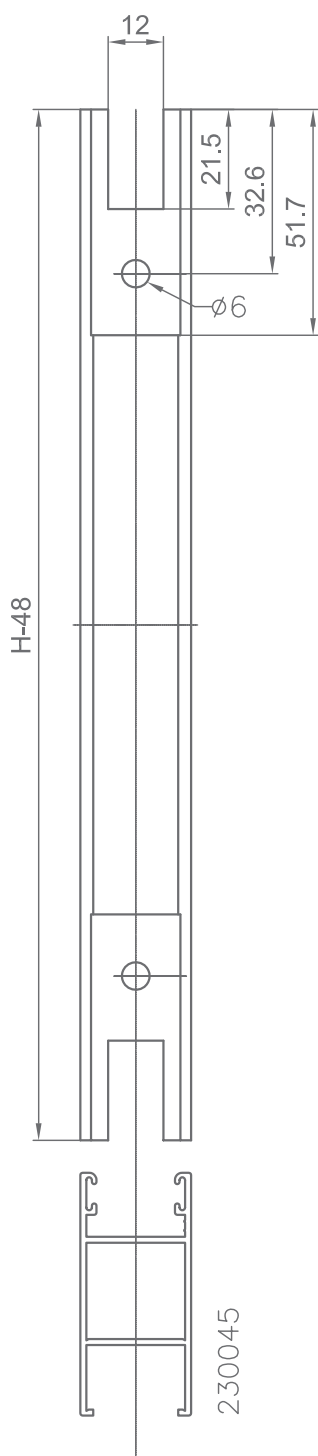
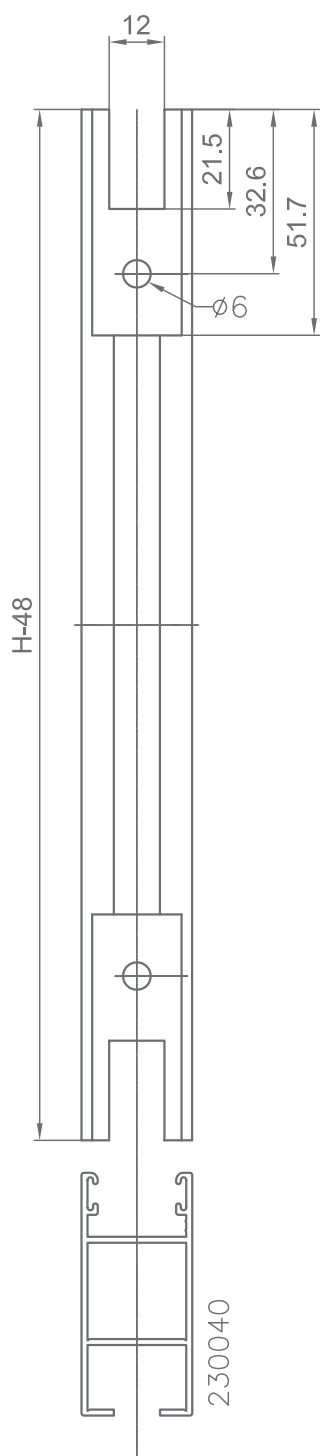



MECANIZADOS | MACHINING

Hoja central  
Central sash

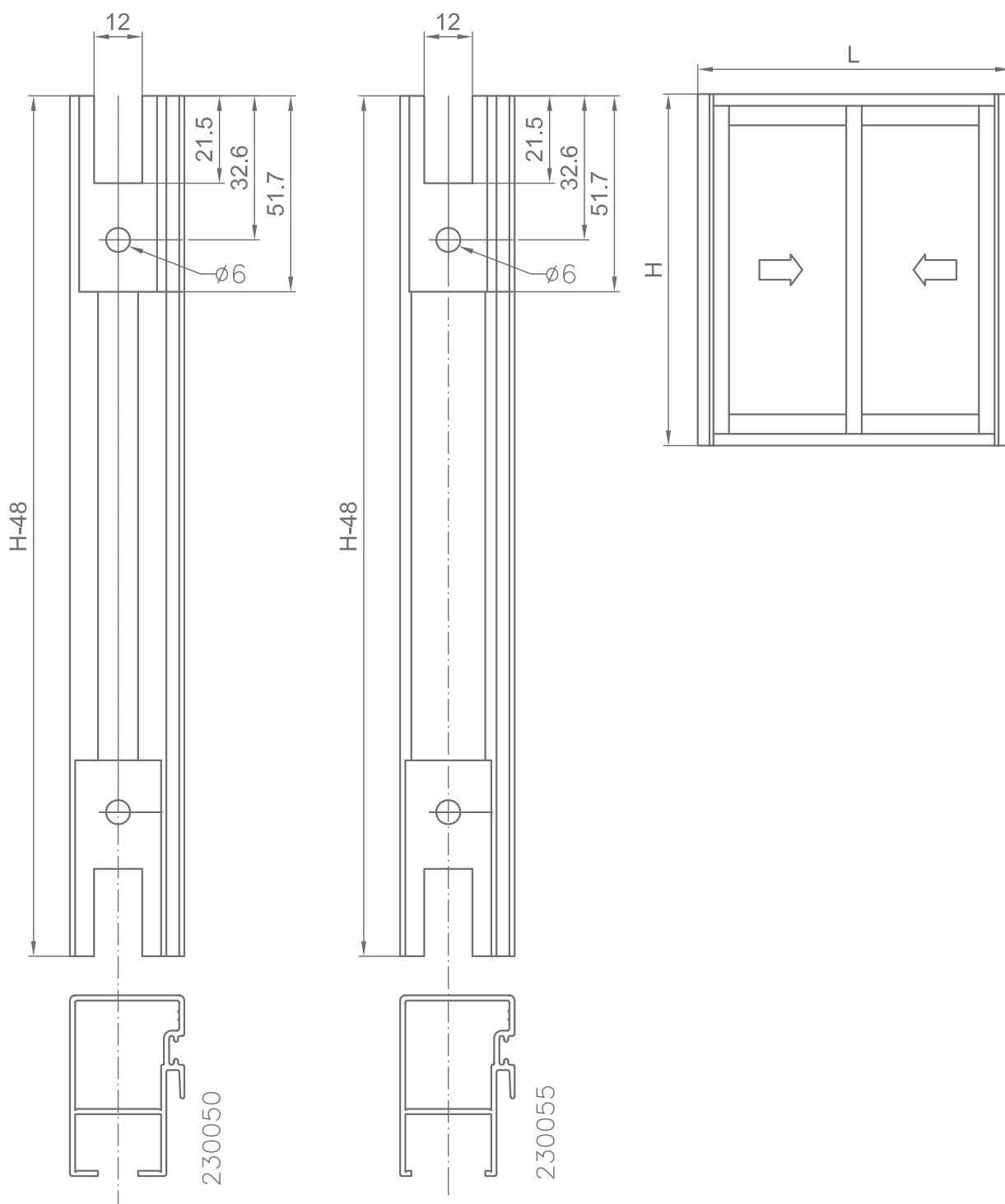

MECANIZADOS | MACHINING

Hoja lateral con zócalo  
Lateral sash with skirting board

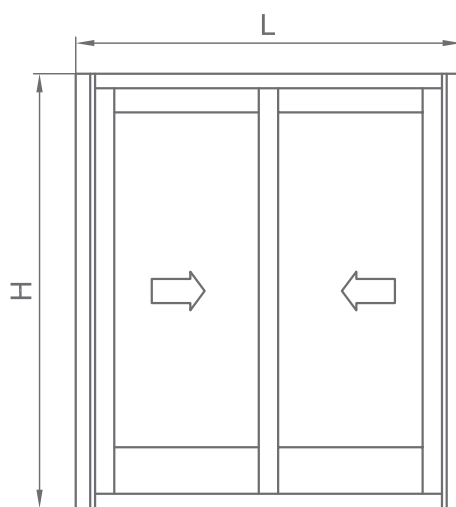
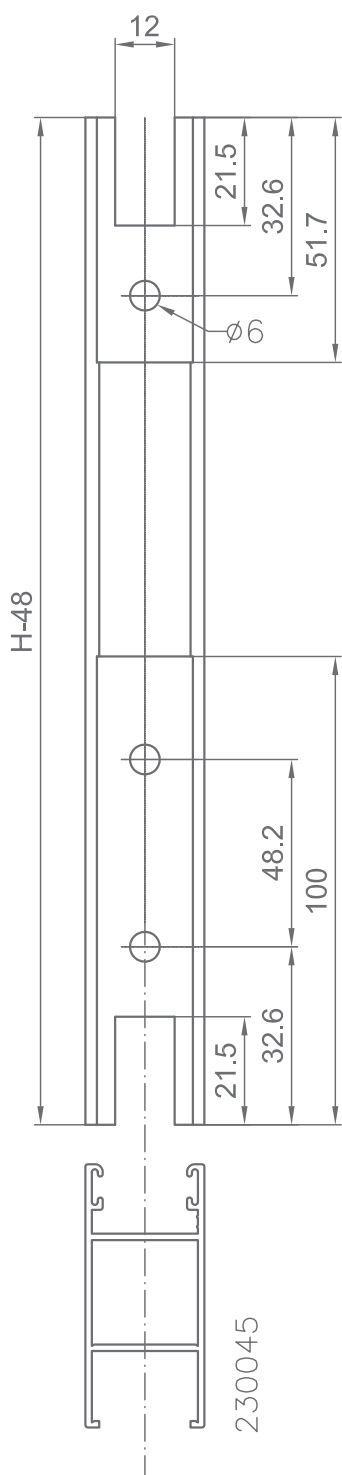
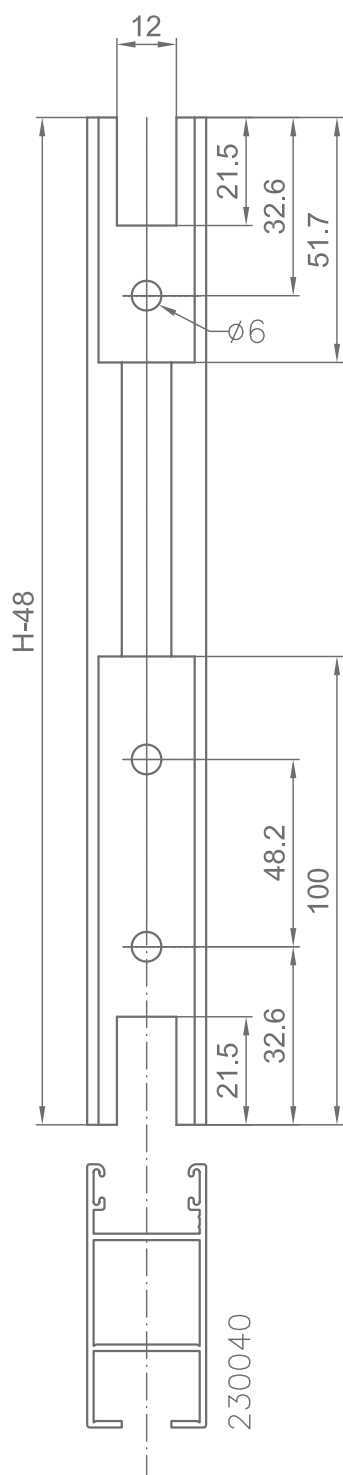

MECANIZADOS | MACHINING

Hoja central con zócalo  
Central sash with skirting board

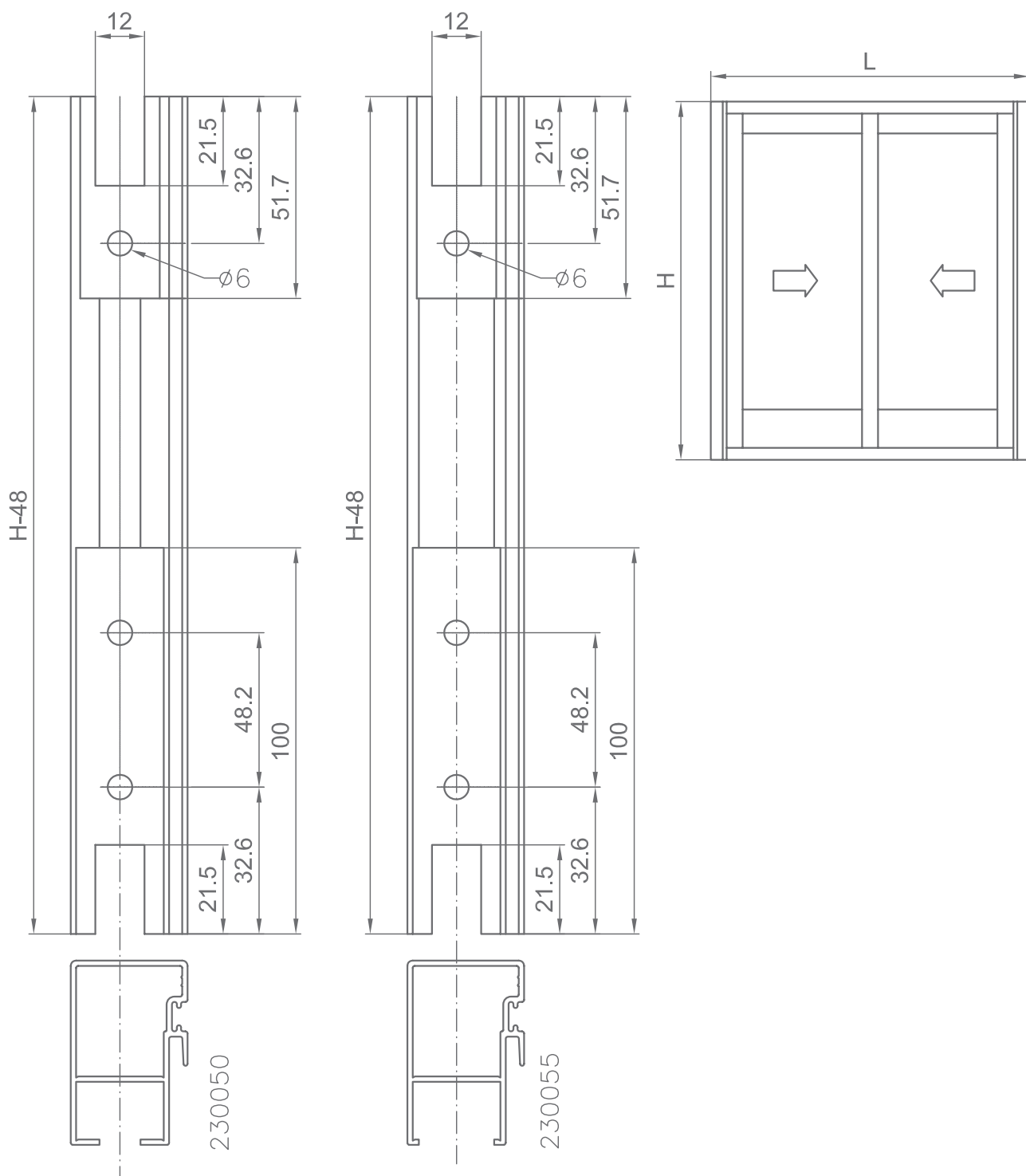



HIERROS  
JÁTIVA

# SERIE 2300

## CORREDERA DE CORTE RECTO STRAIGHT CUT SLIDING

MECANIZADOS | MACHINING

Hoja horizontal, superior e inferior  
Horizontal sash, superior and inferior

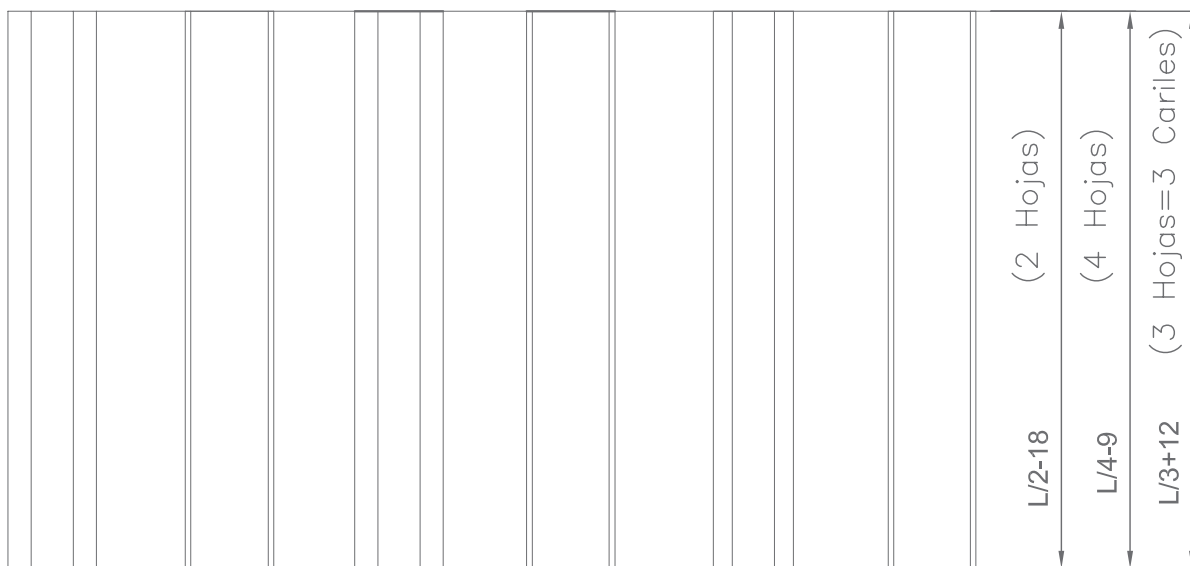
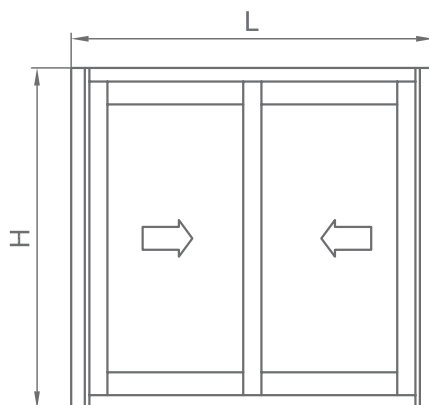

230060



230065



230070



230075



230401

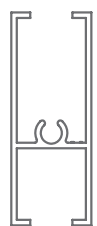

700402

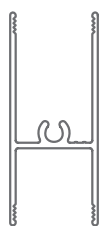





MECANIZADOS | MACHINING

Marco fiho horizontal y vertical  
Fixed frame horizontal and vertical

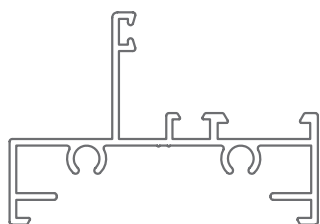

230080

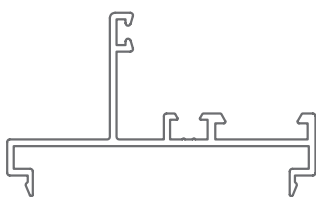

230090

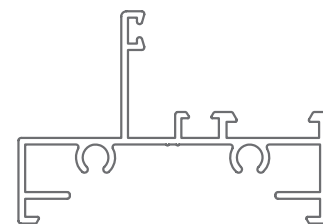
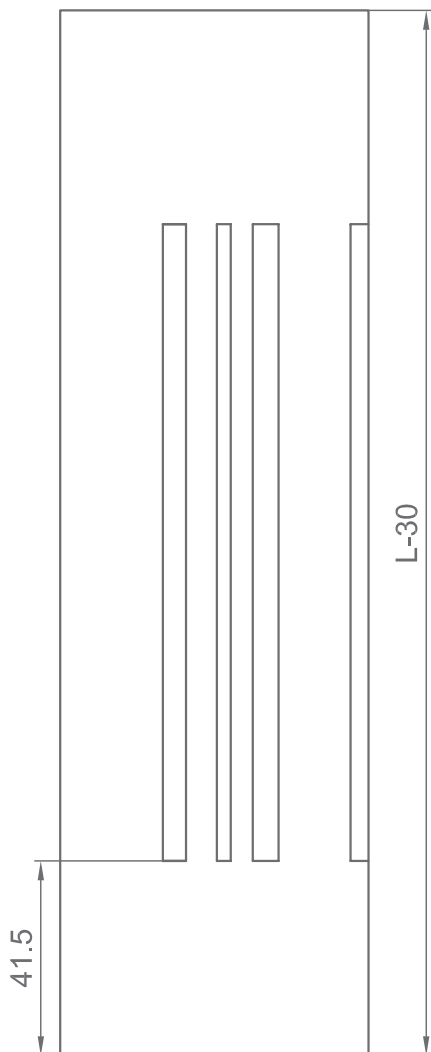
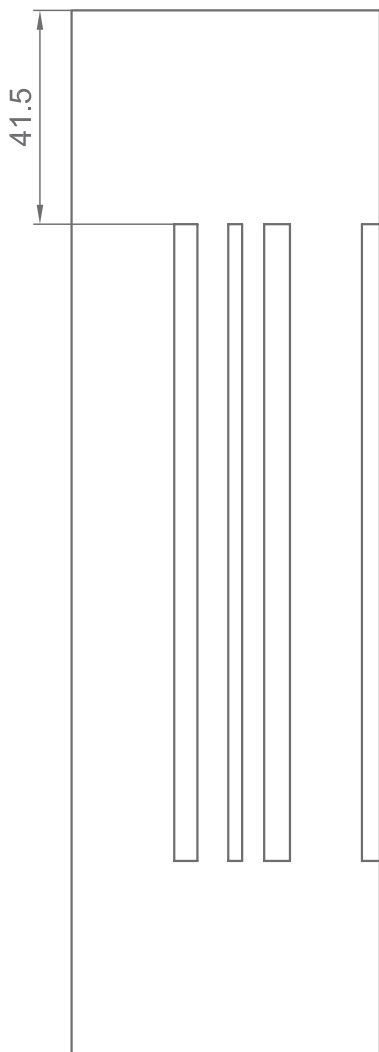
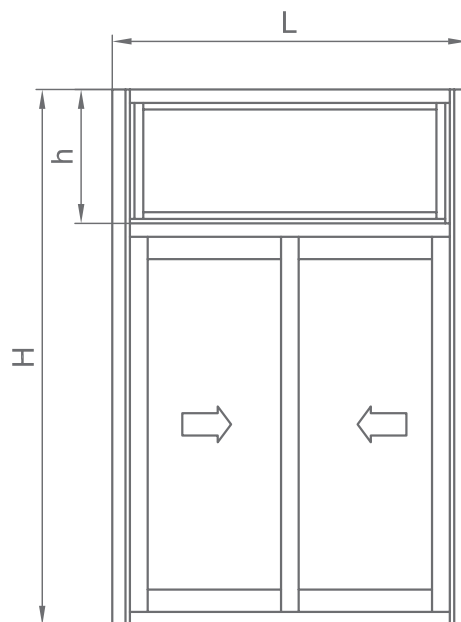

230080

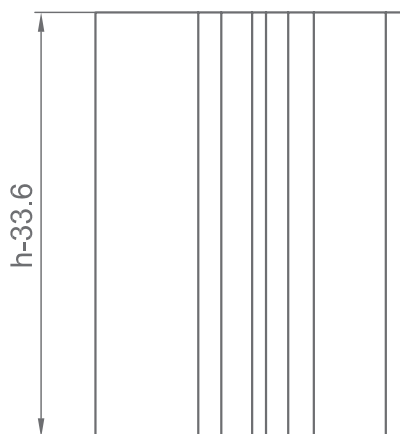



**MECANIZADOS | MACHINING**

Marco fiho horizontal y vertical  
Fixed frame horizontal and vertical

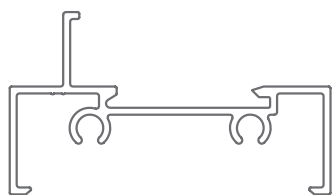

230081

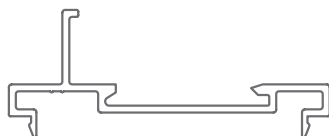

230091

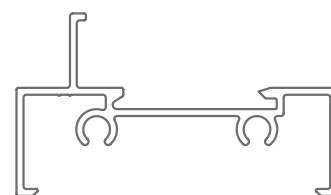
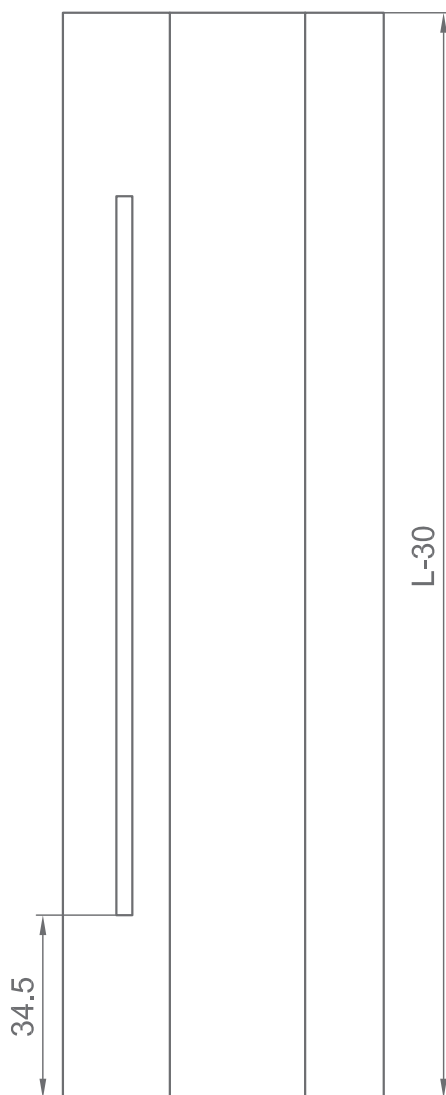
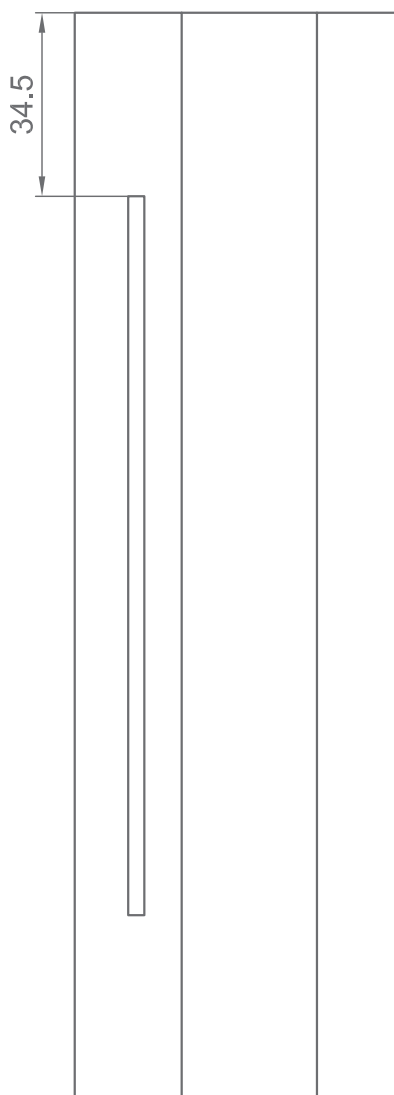
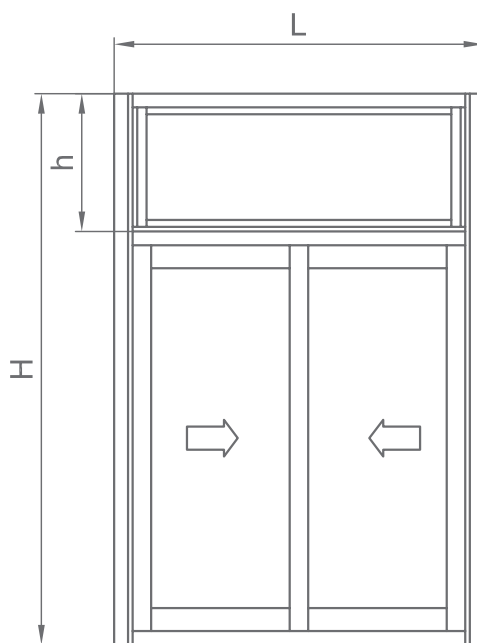

230081

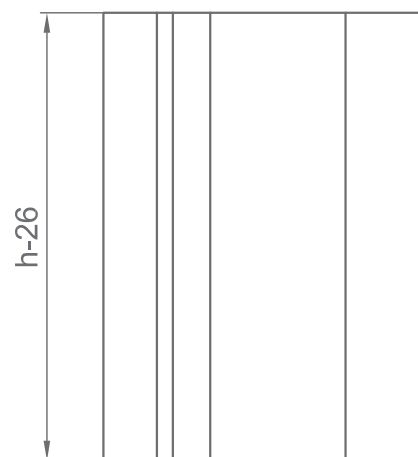





**HIERROS  
JÁTIVA**

**CENTRAL**

Pol.Ind. "La Vila" Parcela 5.  
46819 / Novetlé / Valencia (Spain)  
administracion@hierrosjativa.com

Tel.: 96 227 08 00  
Fax.: 96 227 41 63  
HIERRO: 678 255 770  
ALUMINIO: 678 252 153

.....

**DELEGACIÓN ALICANTE**

Pol.Ind. I-8, Calle Catral  
033330 / Crevillente / Alicante (Spain)  
crevillente@hierrosjativa.com

Tel.: 96 540 45 61  
Fax.: 96 540 46 45

.....

**DELEGACIÓN ZARAGOZA**

Alfredo Abad

alfredoberdusan@gmail.com  
Tel.: 647 576 092