

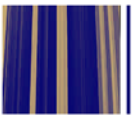

# Profiles

## *Perfiles*



Profiles - *Perfiles*

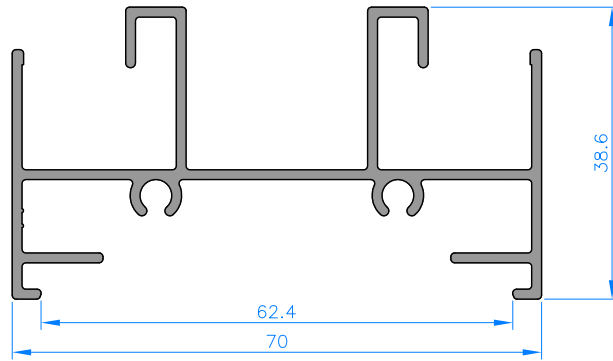

700110

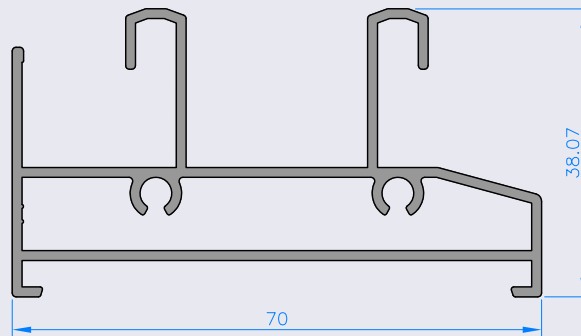

700120

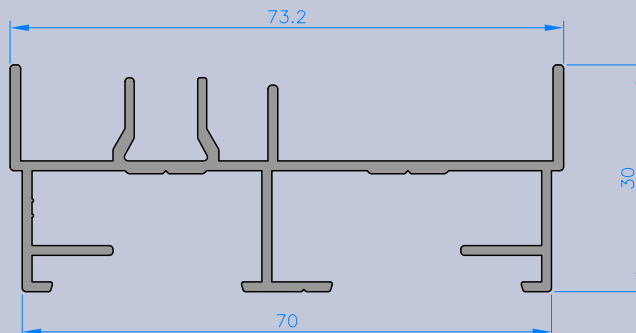

700130



Profiles - *Perfiles*

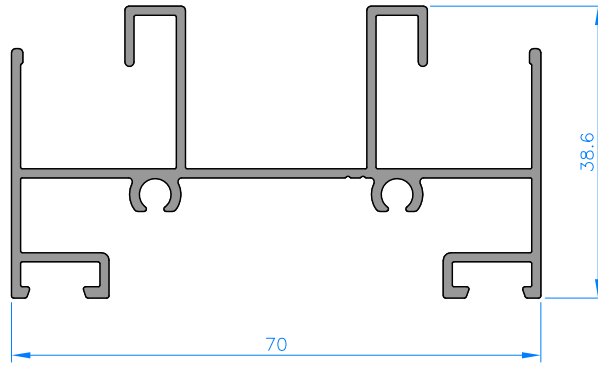

700114

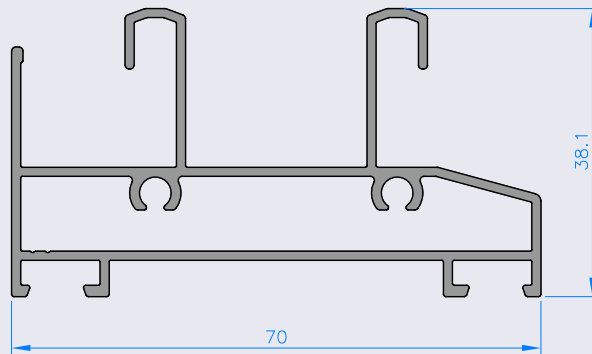

700124

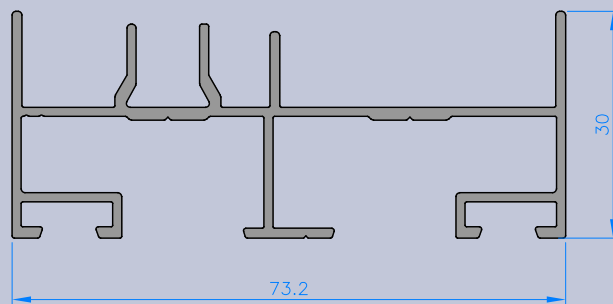

700134

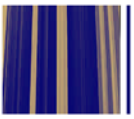

Profiles - *Perfiles*

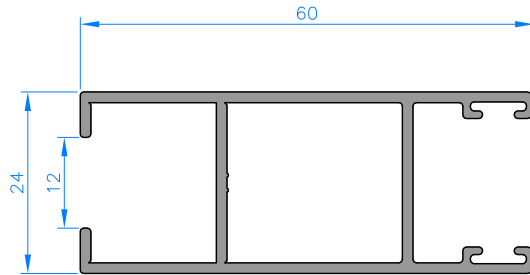

700240

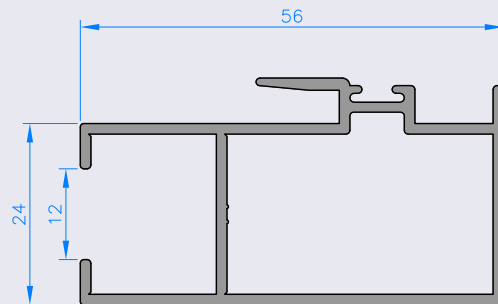

700250

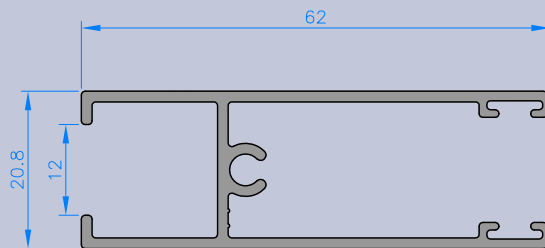

700260



Profiles - *Perfiles*

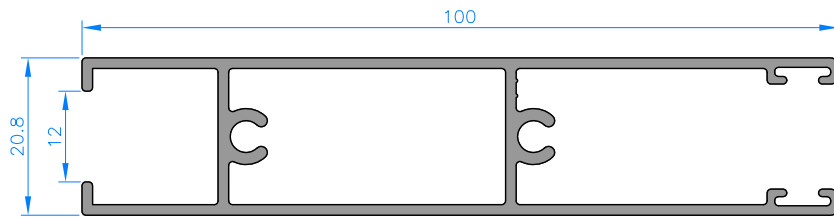

700270

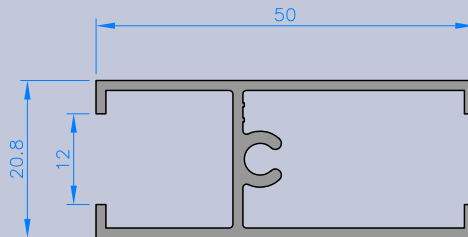

700401

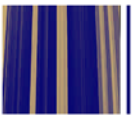

Profiles - *Perfiles*

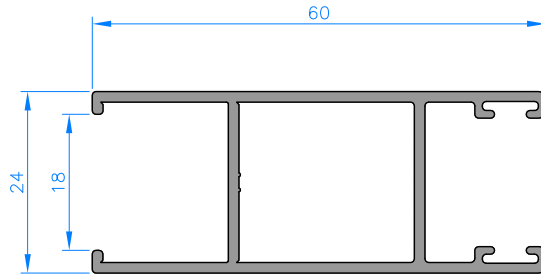

700045

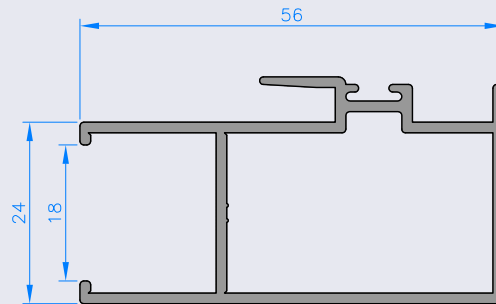

700055

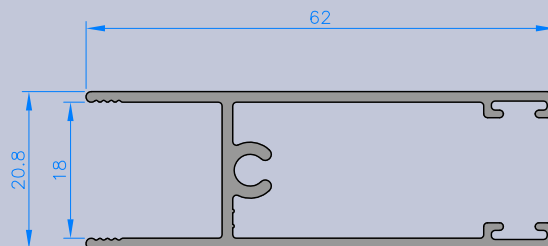

700065



Profiles - *Perfiles*

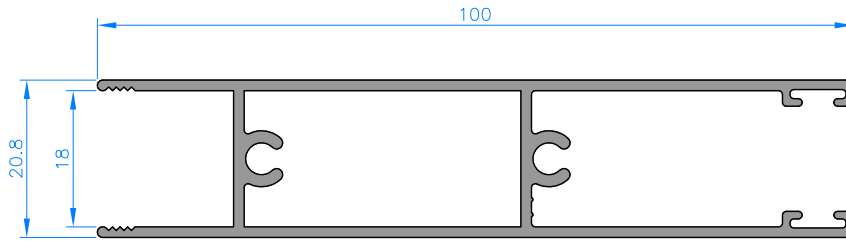

700075

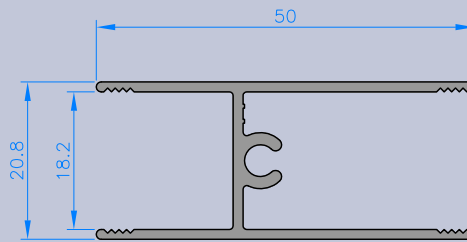

700402



Profiles - *Perfiles*

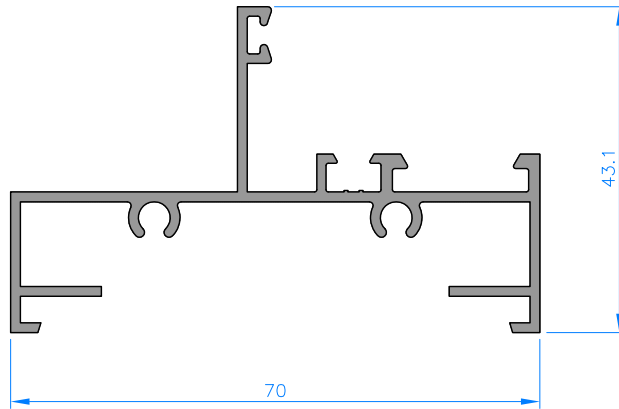

700080

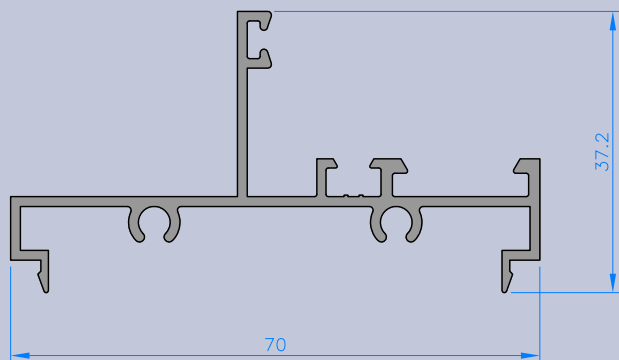

700090



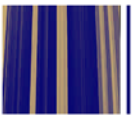

Profiles - *Perfiles*

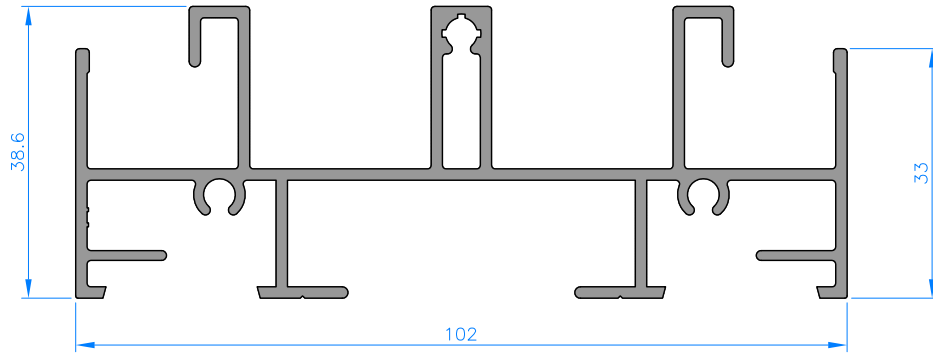

700310

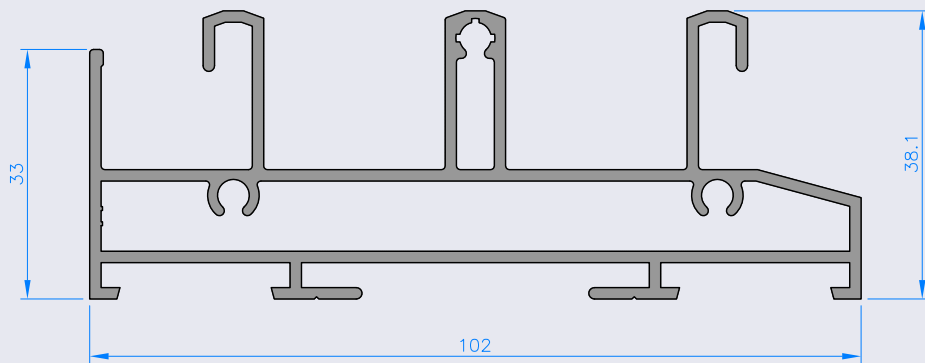

700320

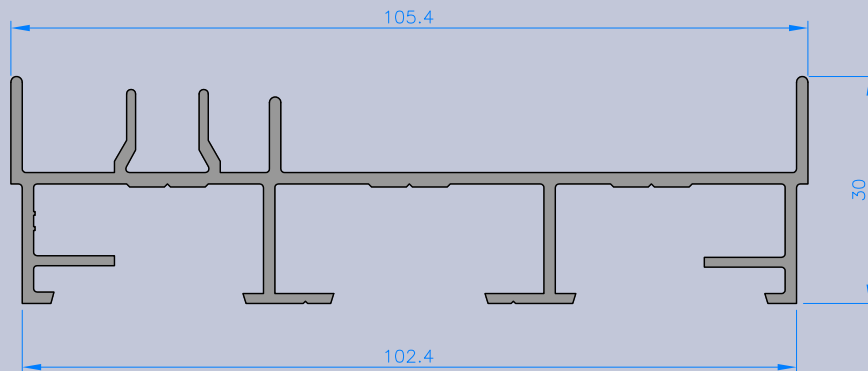

700330



Profiles - *Perfiles*

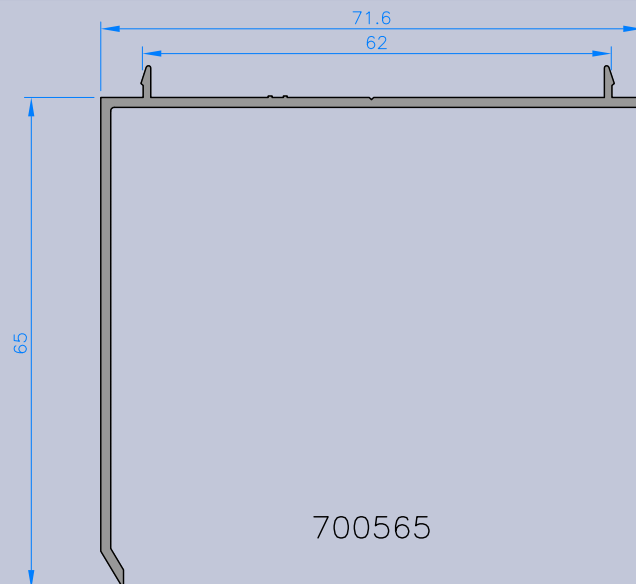
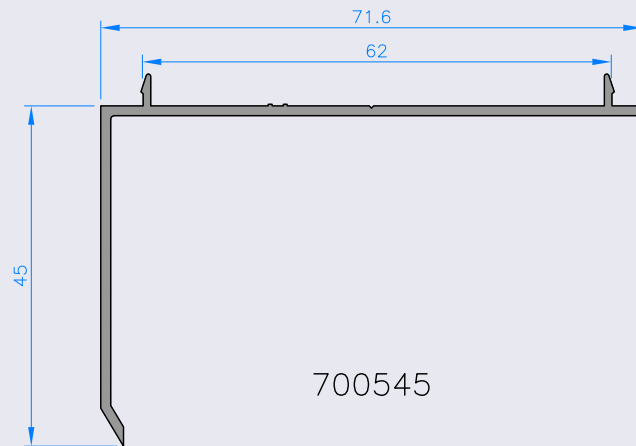
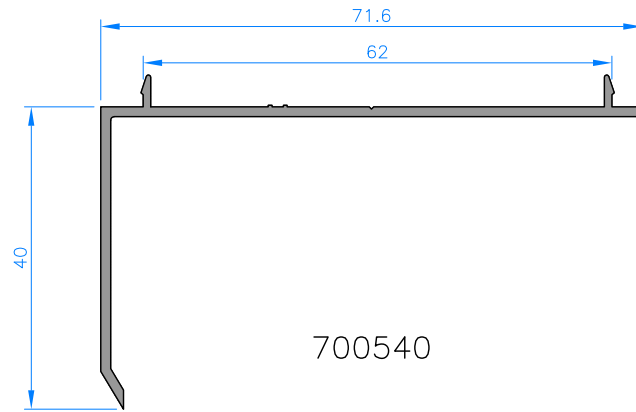



Profiles - *Perfiles*

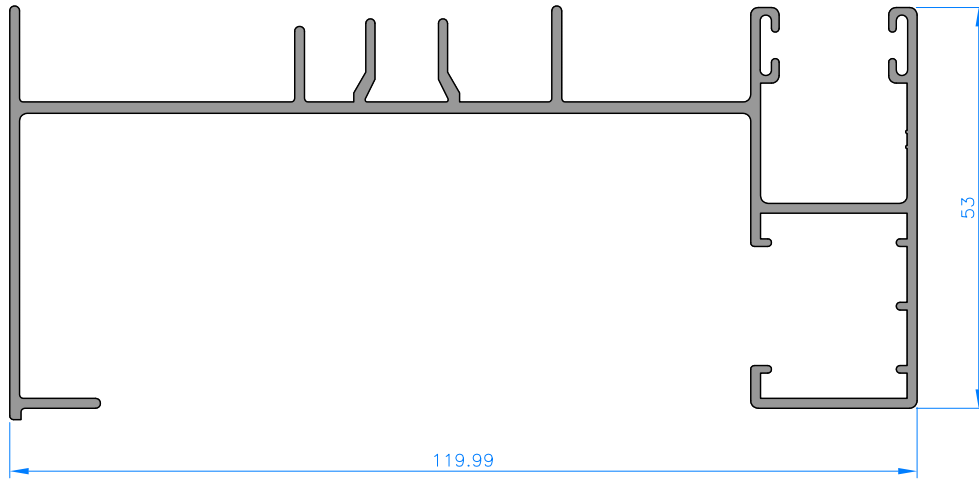

701231

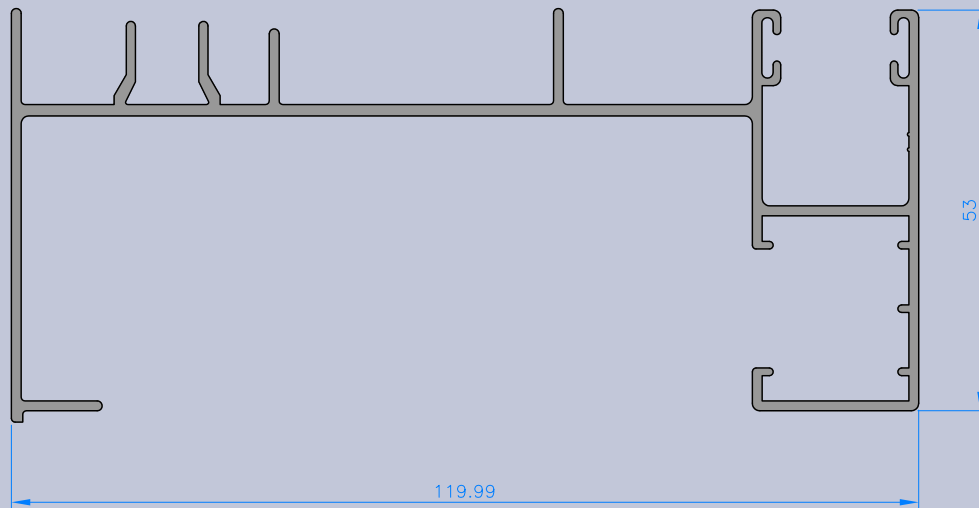

701232

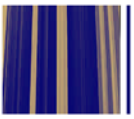

Profiles - *Perfiles*

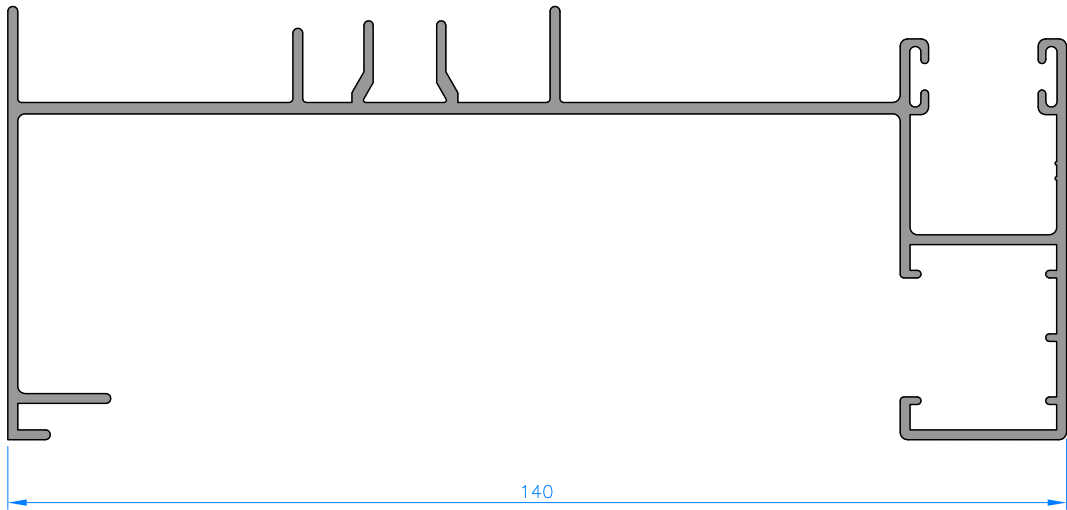

701431

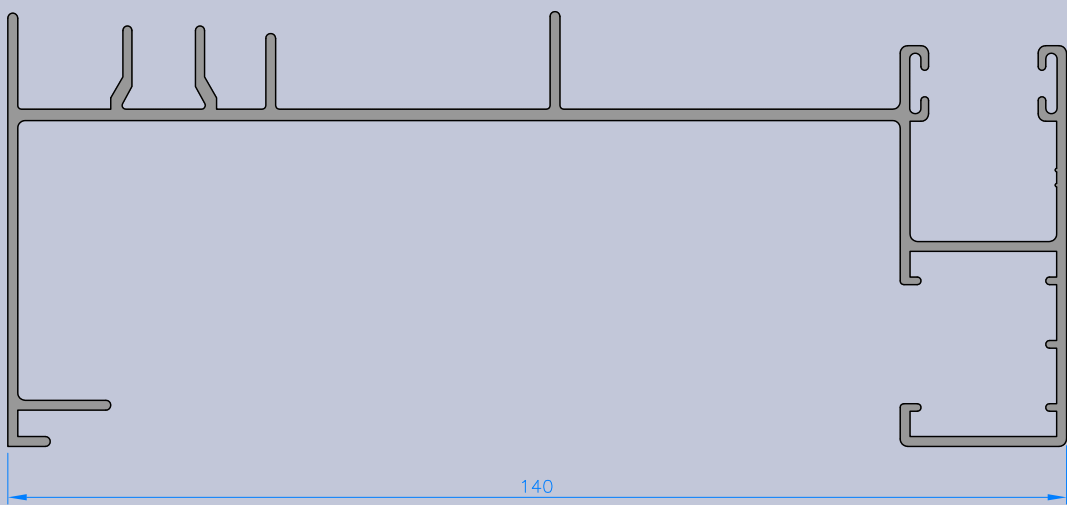

701432



Profiles - *Perfiles*

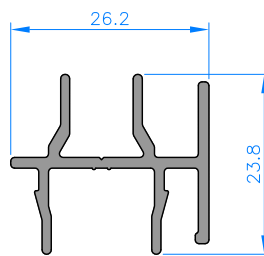

230400



Profiles - *Perfiles*

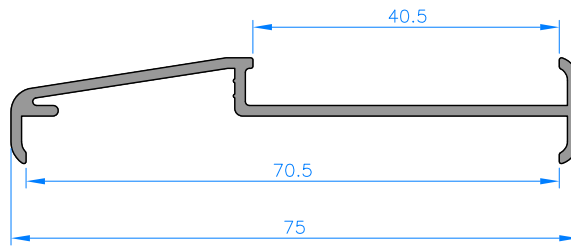

700404

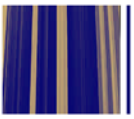

Profiles - *Perfiles*

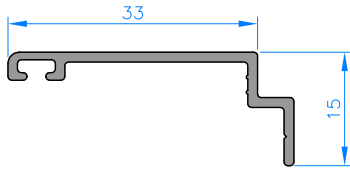

72701

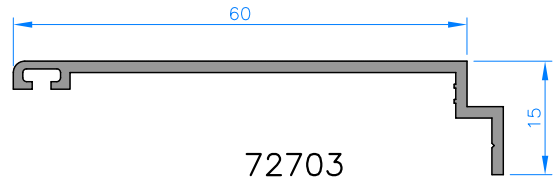

72703

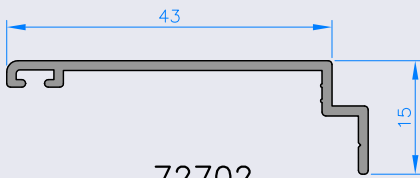

72702

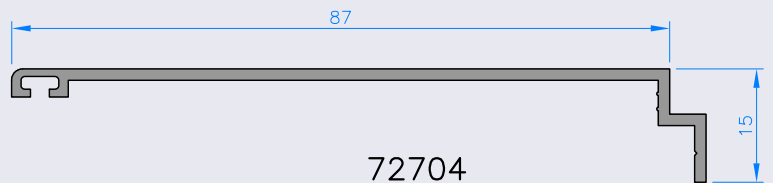

72704

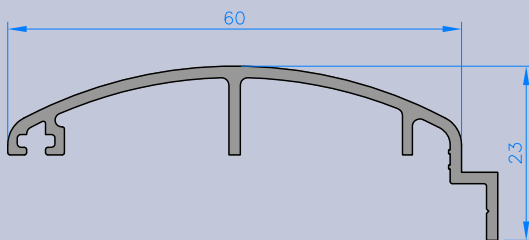

72708

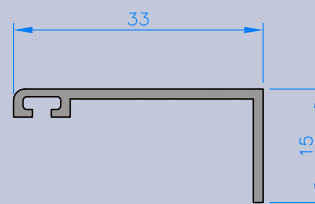

72800\*

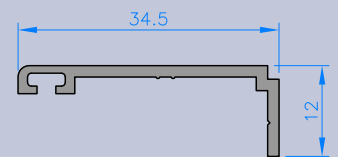

72801

\* Consultar existencias o pedido mínimo

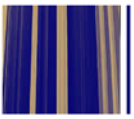

## Profiles - Perfiles

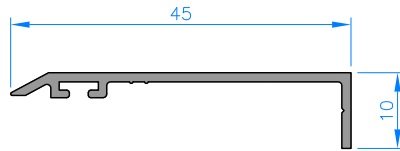

72802

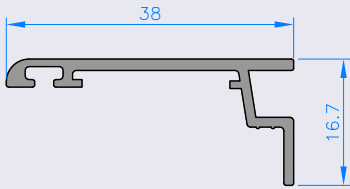

72804

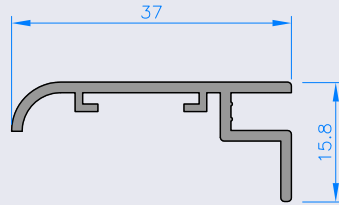

72803

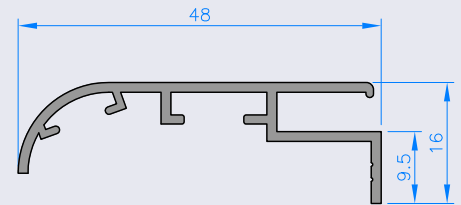

72481

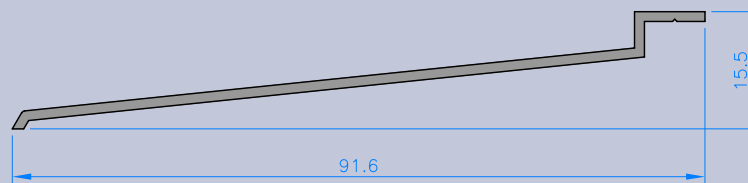

4657\*

\* Consultar existencias o pedido mínimo



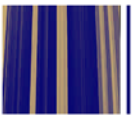

Profiles - *Perfiles*

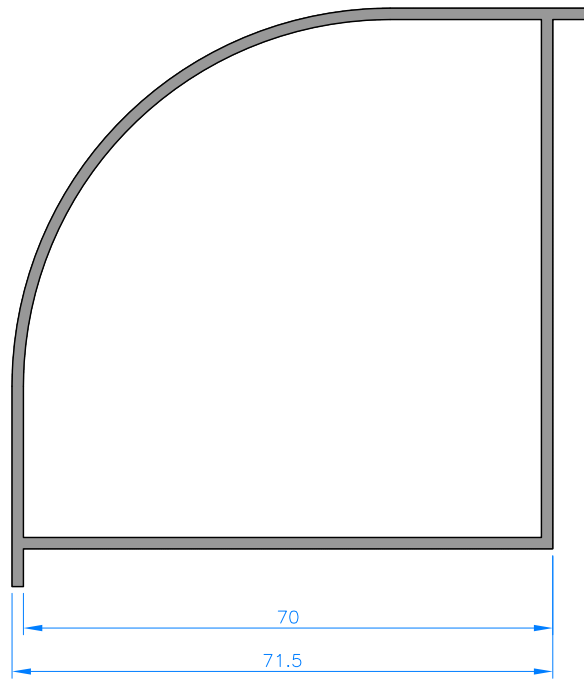

700407 \*



Profiles - *Perfiles*

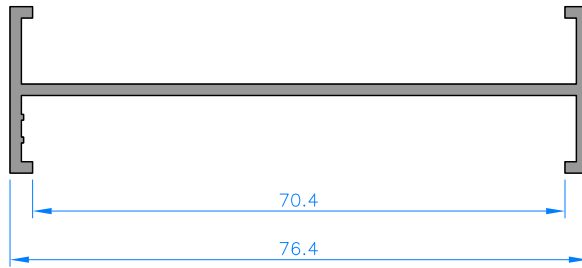

700410



Profiles - *Perfiles*

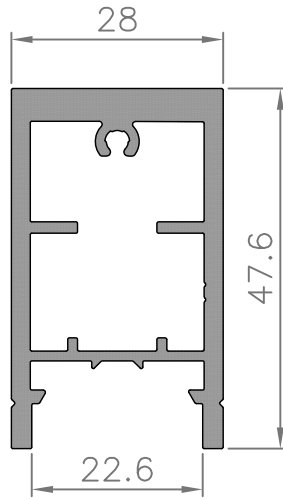

82278

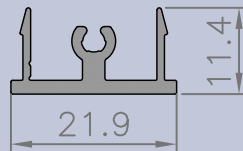

82279



# Glazing

## *Acristalamiento*



# Glazing - Acristalamiento

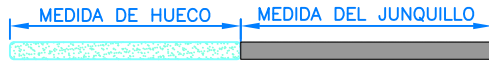

Para calcular el vidrio:

Descontar la medida de juntas, según indicaciones del fabricante.

9998216		3 MM FIN EXT. GLAZING JOINT JUNTA ACRISTALAMIENTO EXTERIOR DE 3 MM.
9998226		6 MM FIN EXT. GLAZING JOINT JUNTA ACRISTALAMIENTO EXTERIOR DE 6 MM.
9998236		3 MM FIN INT. GLAZING JOINT JUNTA ACRISTALAMIENTO DE CUÑA DE 3 MM.
9998246		4 MM FIN INT. GLAZING JOINT JUNTA ACRISTALAMIENTO DE CUÑA DE 4 MM.
9998256		5 MM FIN INT. GLAZING JOINT JUNTA ACRISTALAMIENTO DE CUÑA DE 5 MM.
9998266		6/7 MM FIN INT. GLAZING JOINT JUNTA ACRISTALAMIENTO DE CUÑA DE 6/7 MM.
9998286		8/9 MM FIN INT. GLAZING JOINT JUNTA ACRISTALAMIENTO DE CUÑA DE 8/9 MM.
9998296		10 MM FIN INT. GLAZING JOINT JUNTA ACRISTALAMIENTO DE CUÑA DE 10 MM.

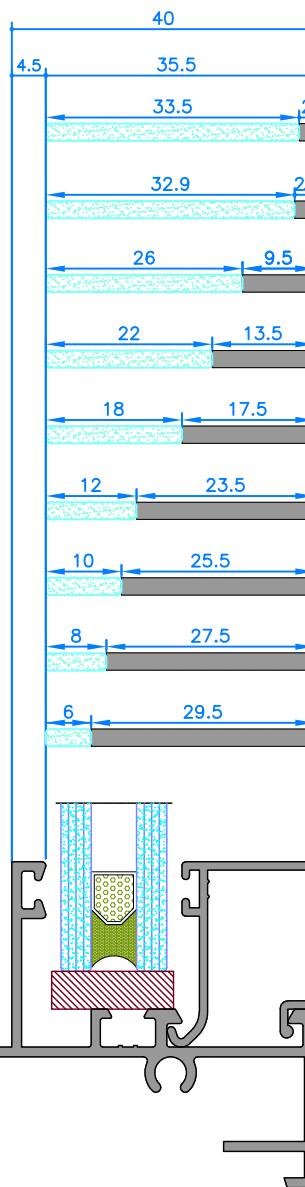

102308		
	940305	
940304	940314	940324
940303	940313	940323
940302	940312	940322
940301	940311	940321
940306		
850307		
940300	940310	940320

80 ∞U - ° oyk-o) -h-V) @8\ V'u=- \h-V@8u h-  
U-) @° o) - t@k@ )-h-V) @V) \ ) -Ou@ \ ) - ° h-kuyk°

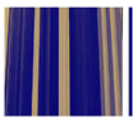

## Glazing - Acristalamiento

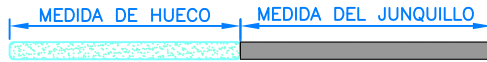

Para calcular el vidrio:

Descontar la medida de juntas, según indicaciones del fabricante.

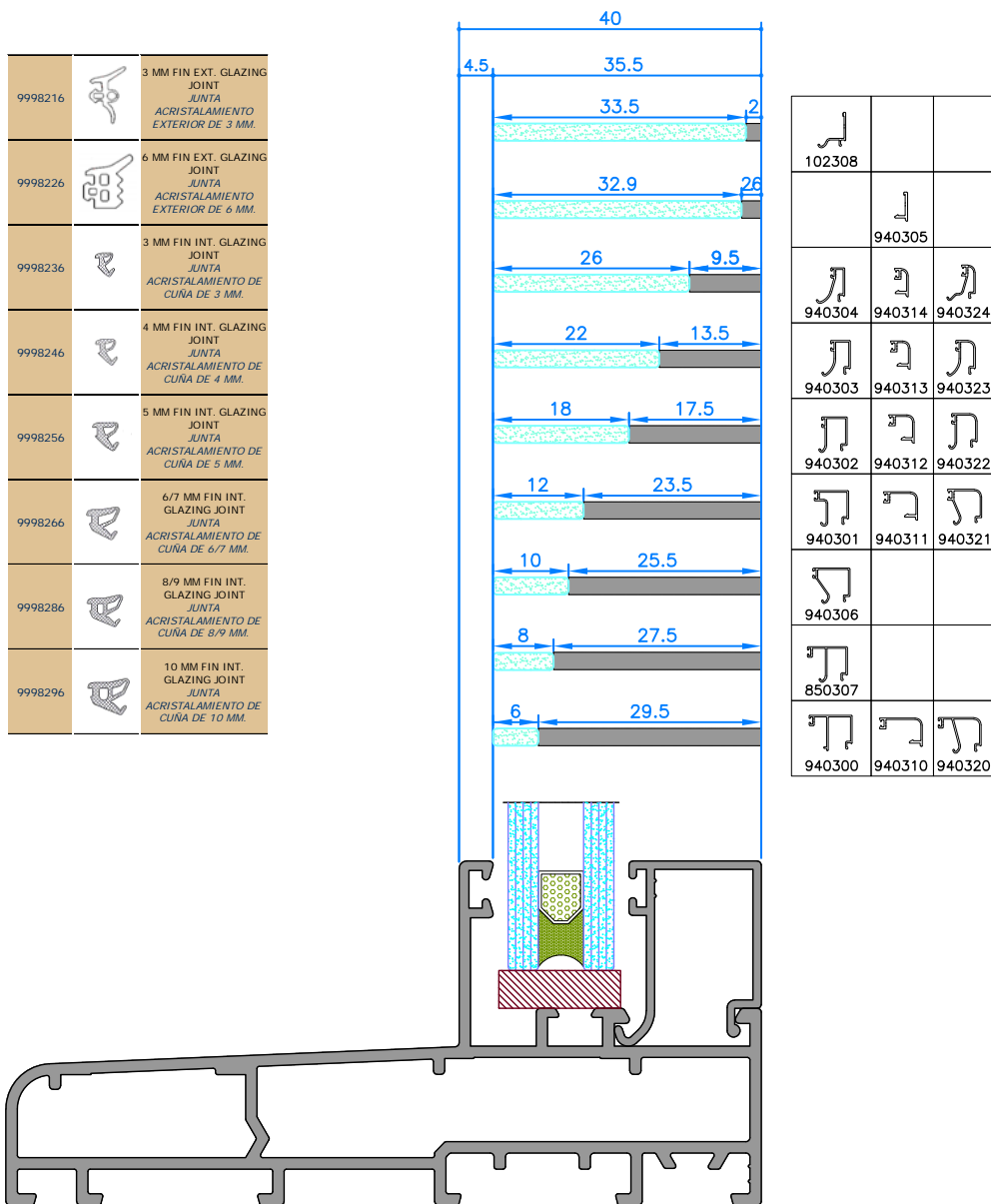

80 ∞U - ° oyk-o) -h-V) @8\ V'u=- \h-V@8u h-  
U-) @° o) - t@k@ )-h-V) @V) \ ) -Ou@ \ ) - ° h-kuyk°



o

o

